

VOLVO 480c

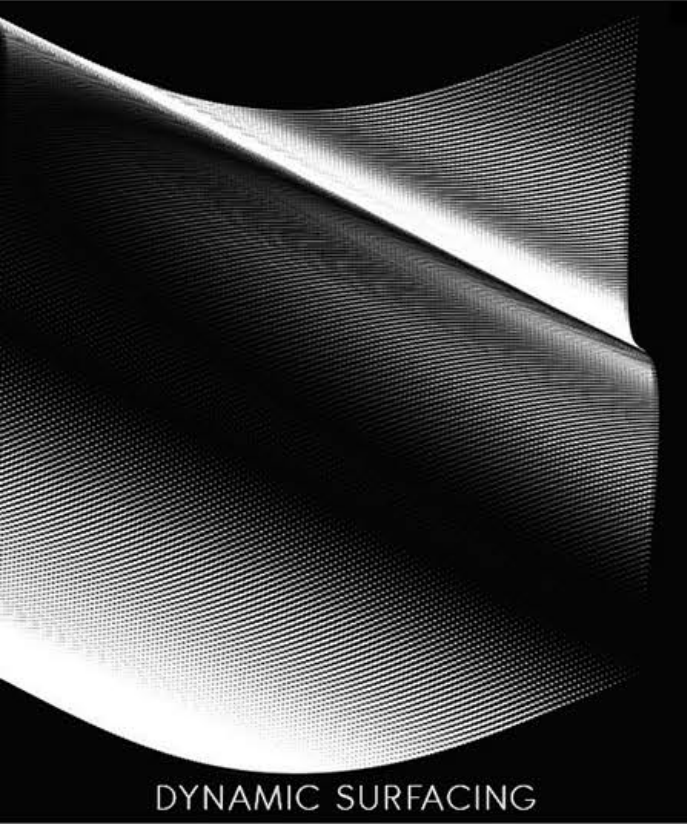

DYNAMIC SURFACING



MONOLITHIC LOOK



TECHNOLOGY BOX



480C

480c

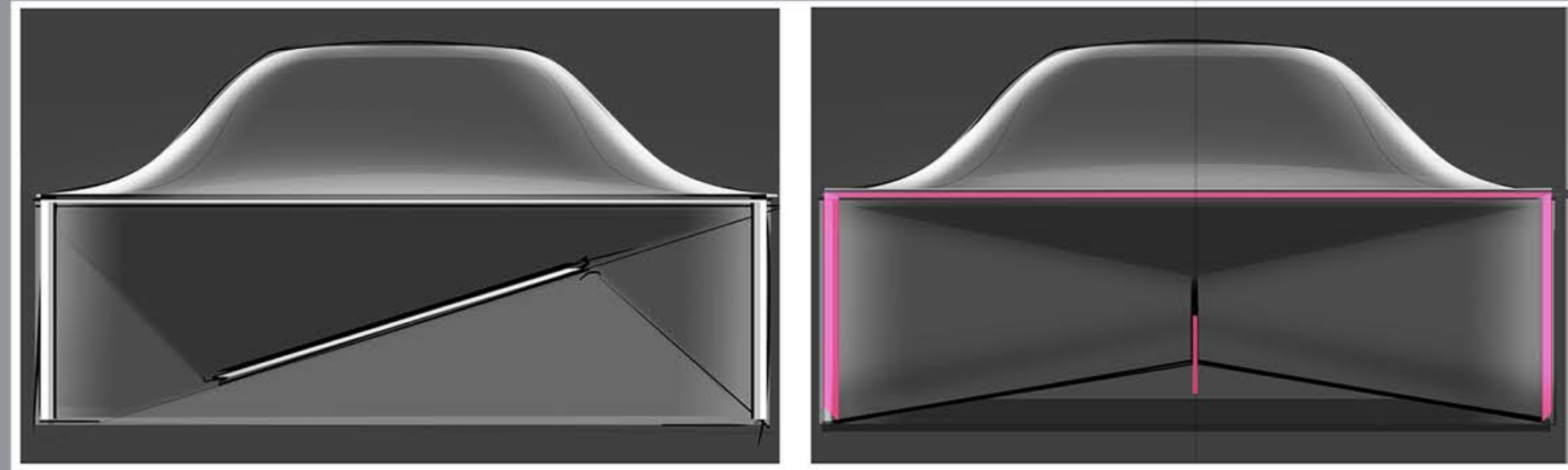
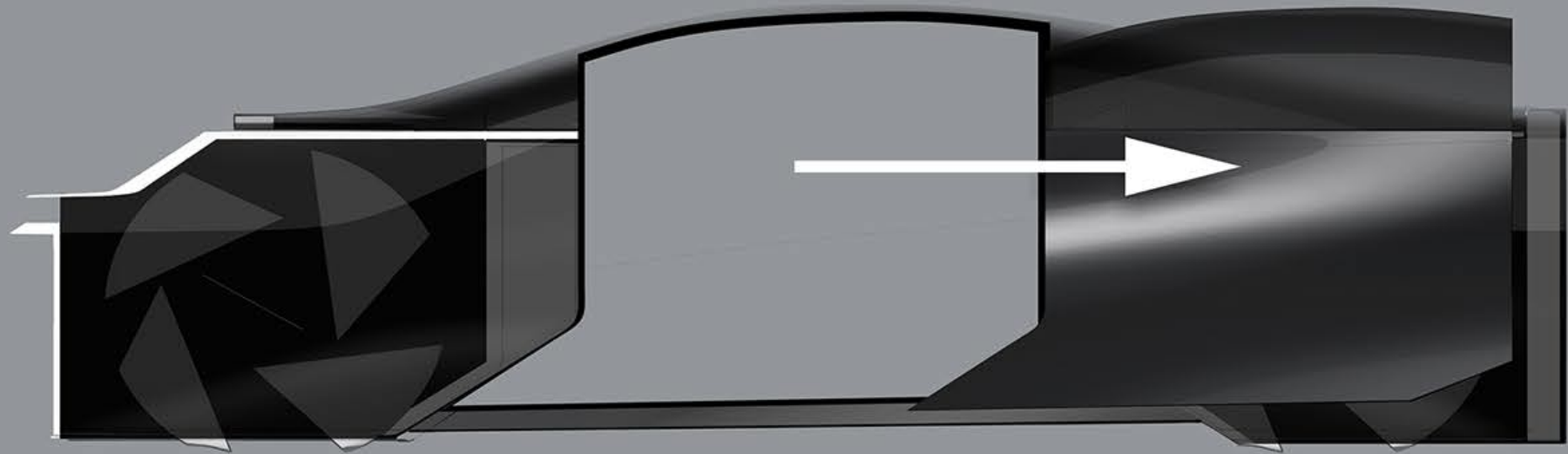
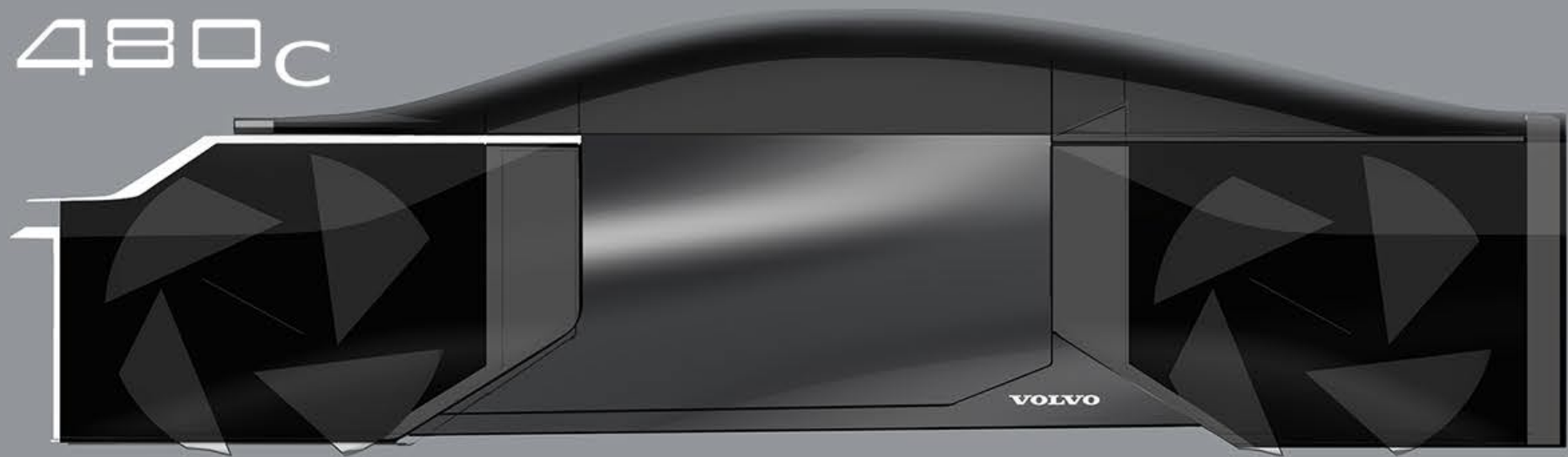

Researching **STRICKING-YET-SIMPLE** silhouette
that merges **SOLIDITY** and **FLOWING** lines

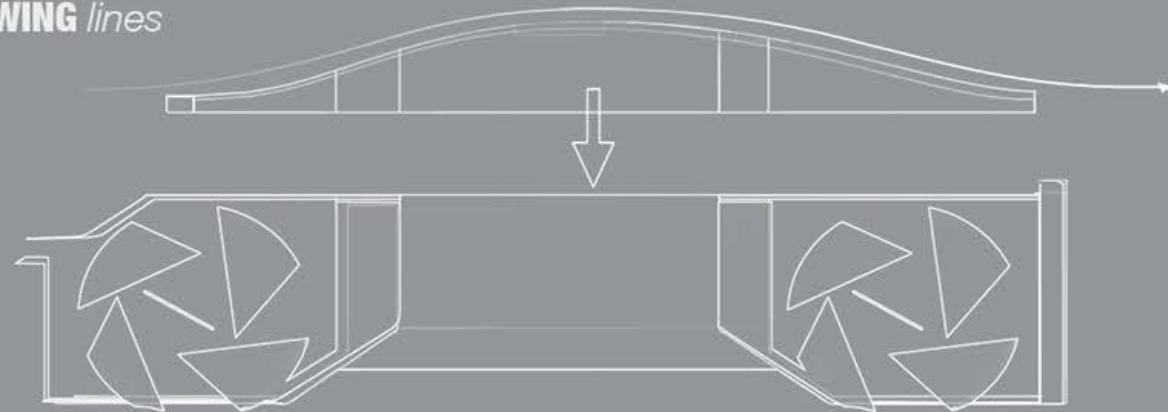



Ideation Sketches

*key element is the **CONTRAST OF GLASS AND BODY**
that visually express a **FUSION OF SOLIDITY AND LIGHTNESS***

Merging **SOLID-MONOLITHIC** presence with **FULL-SENSUAL** surfacing
maintaining **THOR'S HAMMER** signature

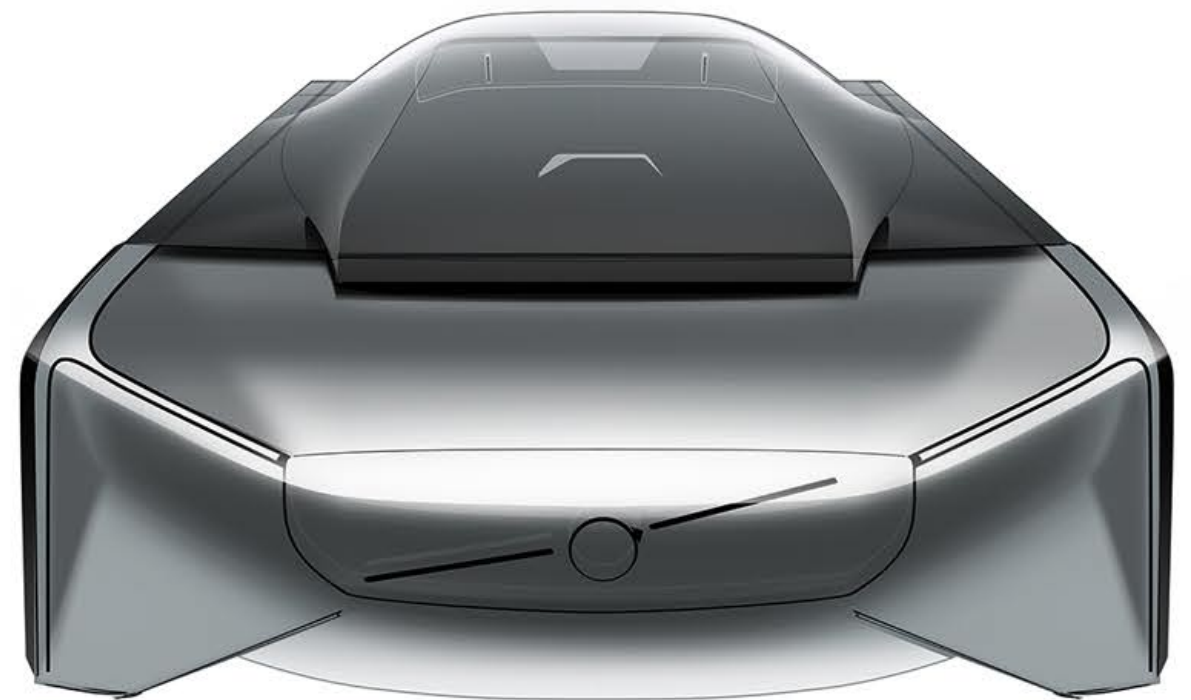
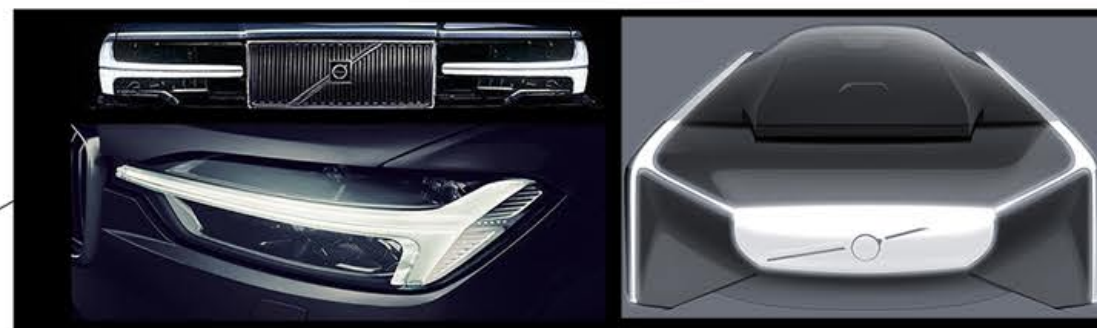
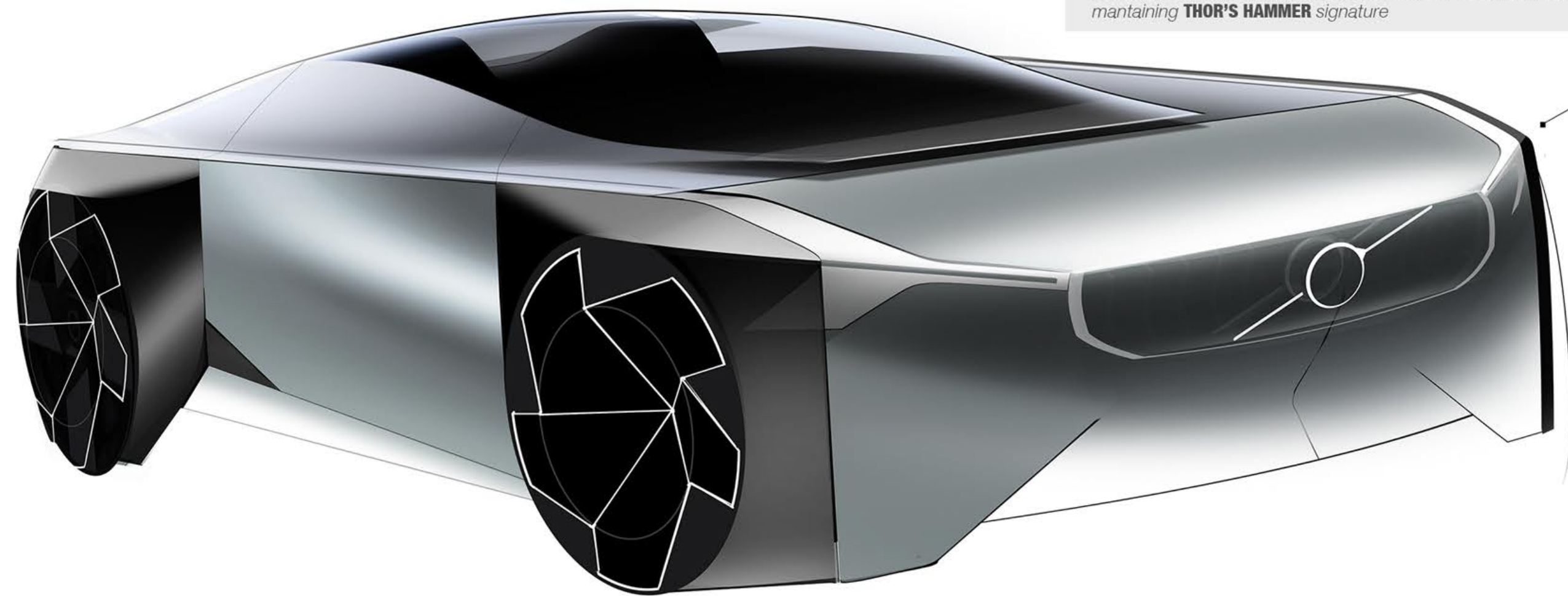

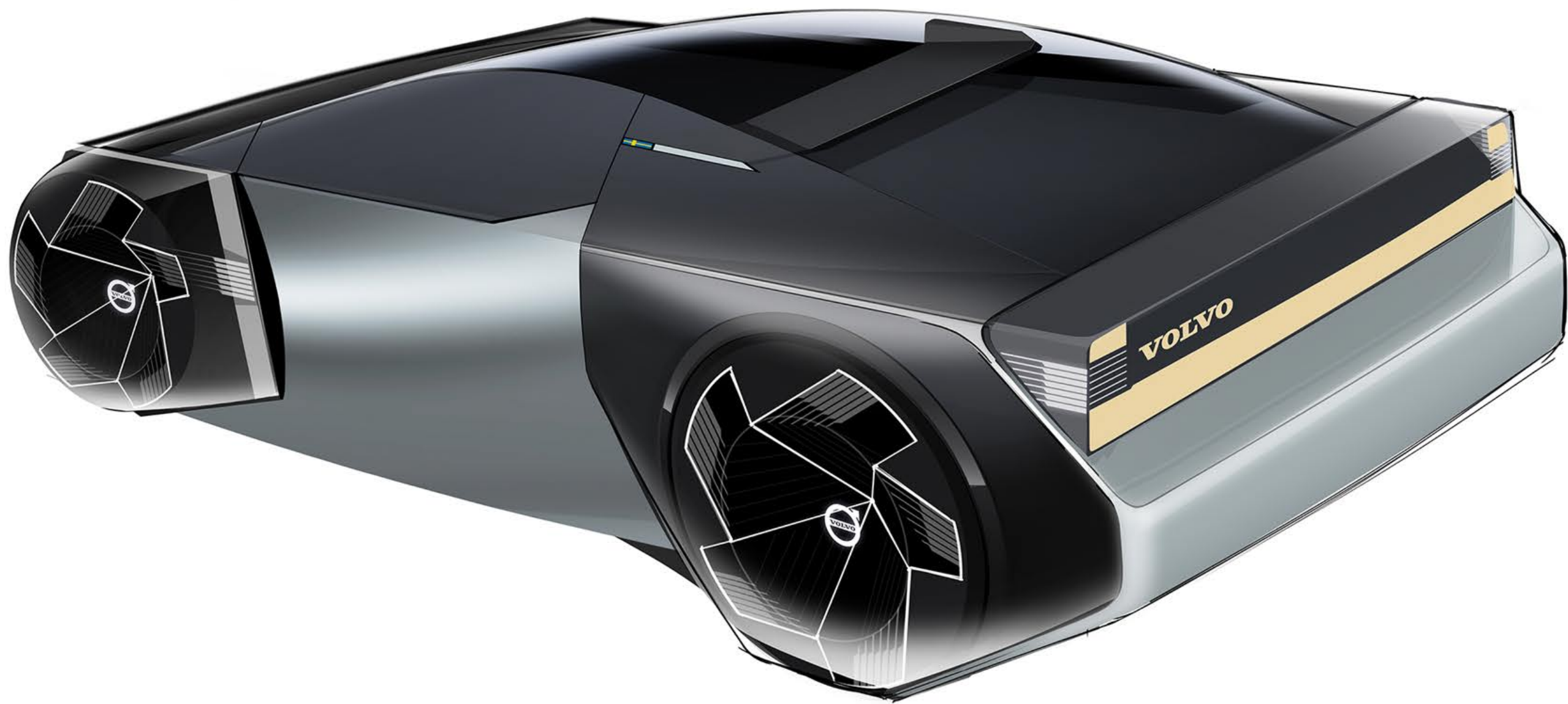

*the **SOLID-MONOLITHIC** theme translates in the **REAR LIGHTING ELEMENTS**
a **SOLID BLOCK OF CRYSTAL** lits up with typical **VOLVO GRAPHICAL SIGNS***

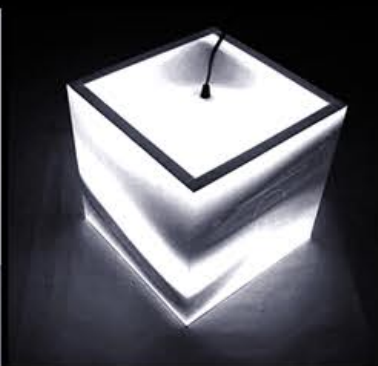

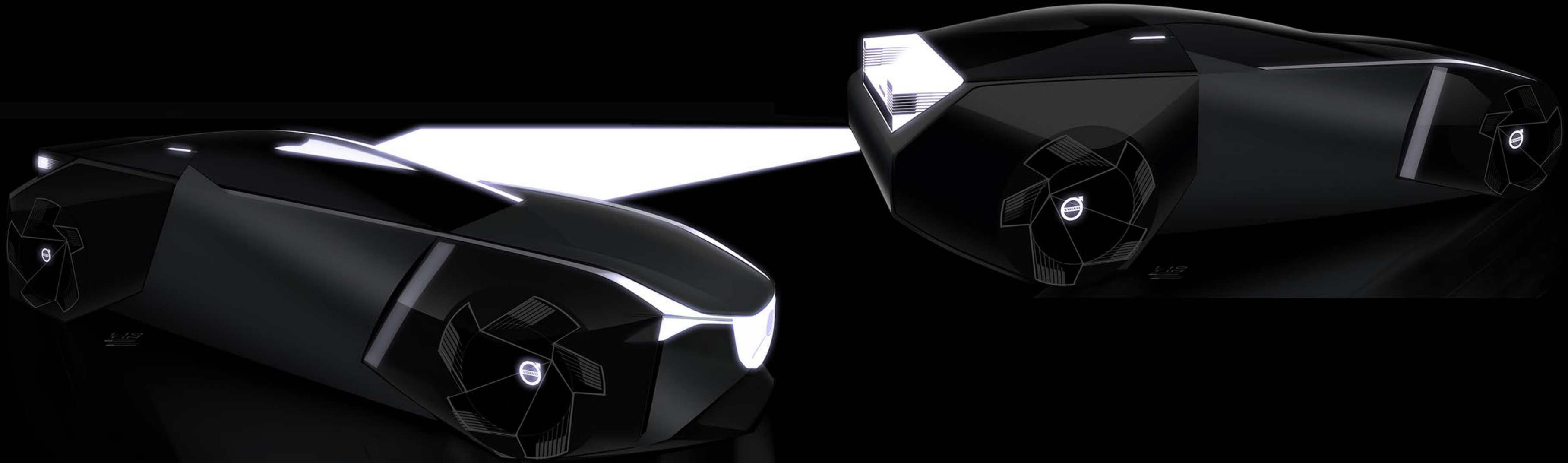

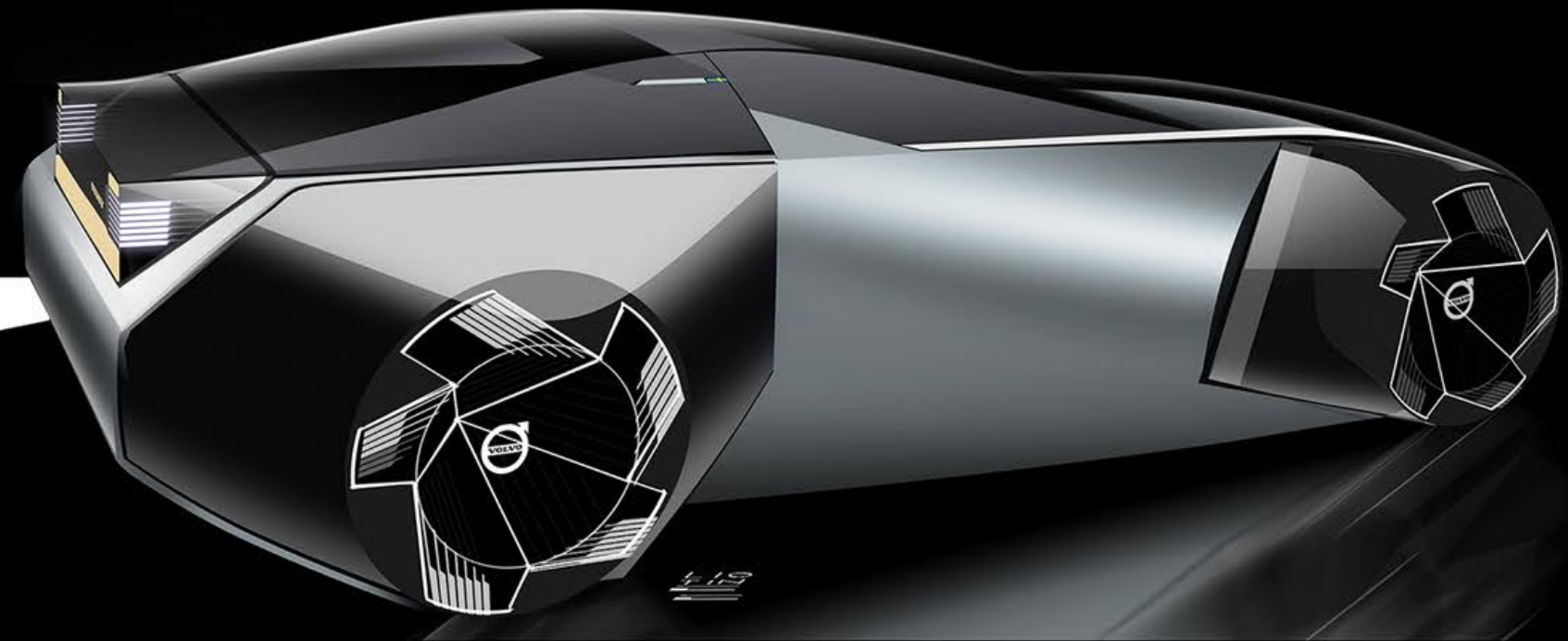
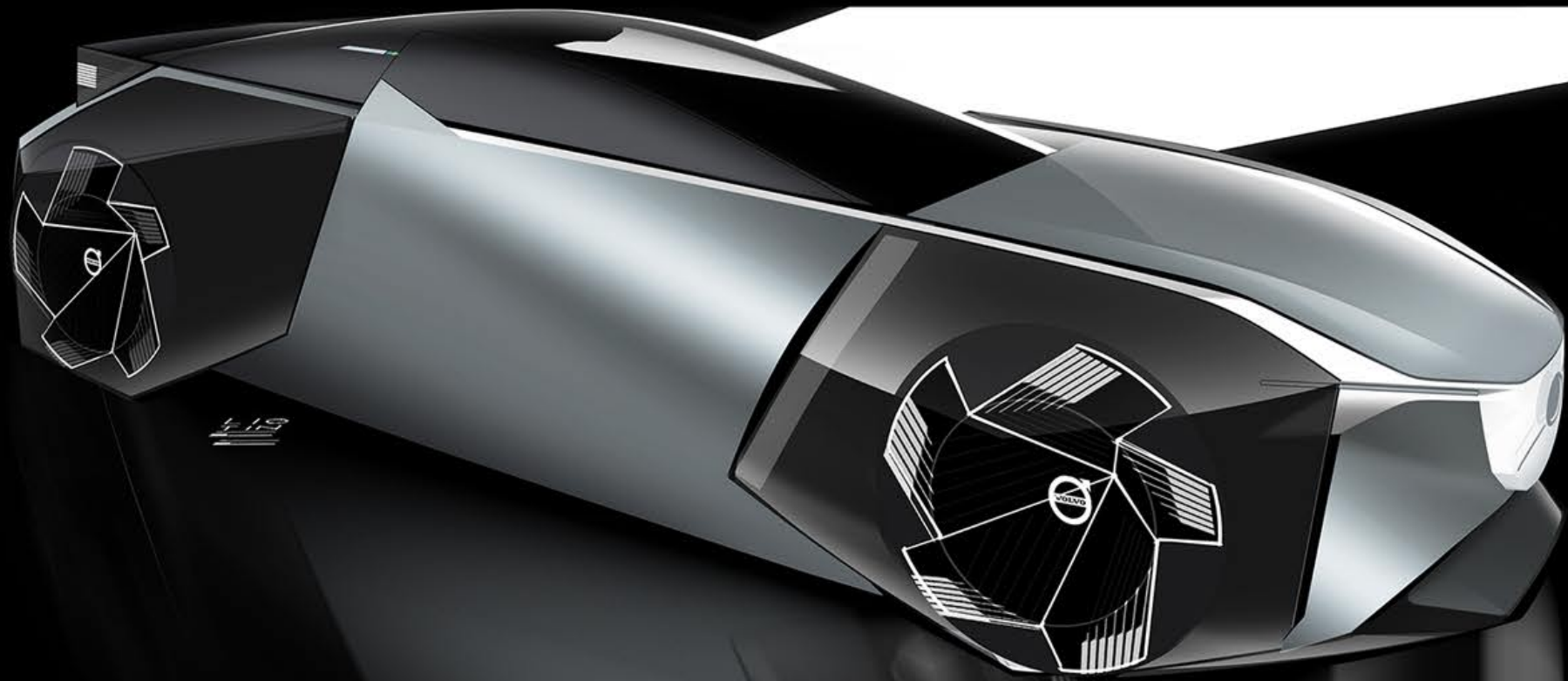

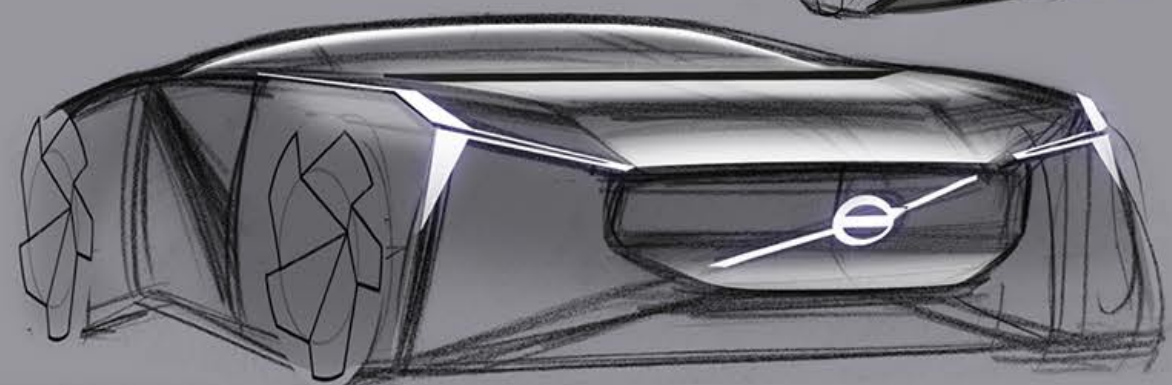
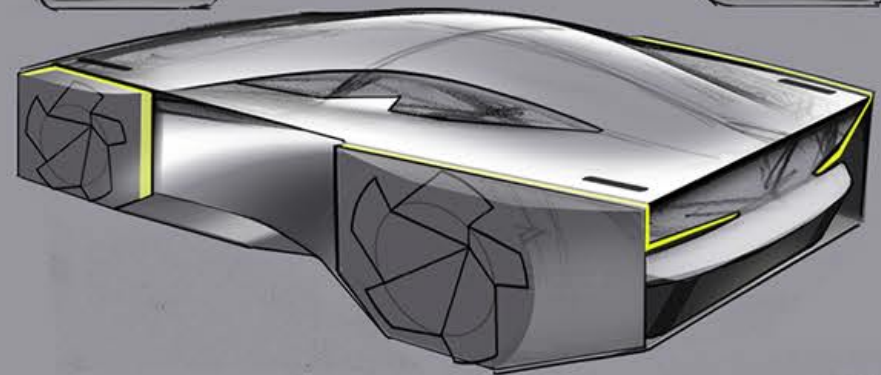
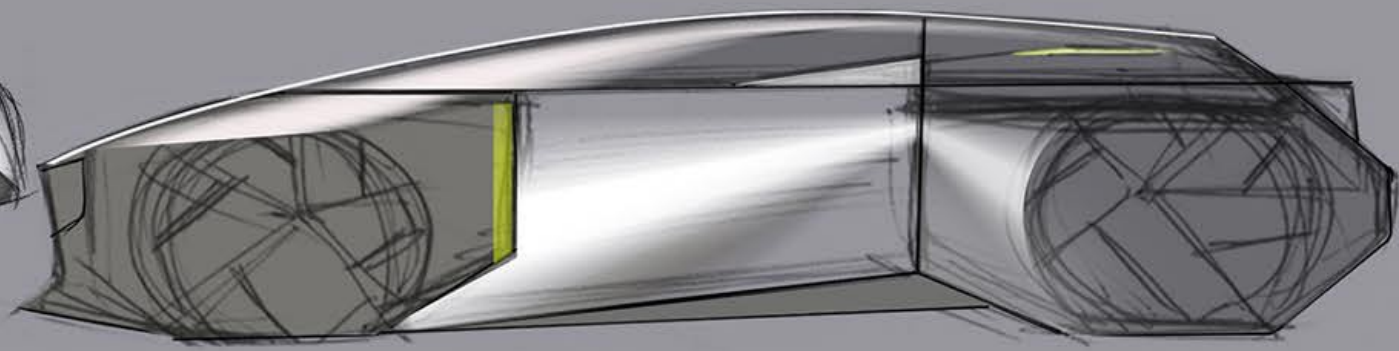
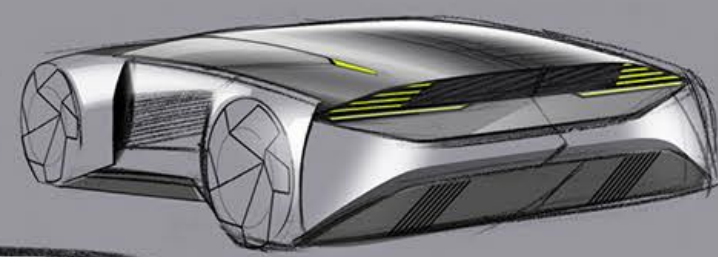

Researching toward a **HATCHBACK-480** inspired solution

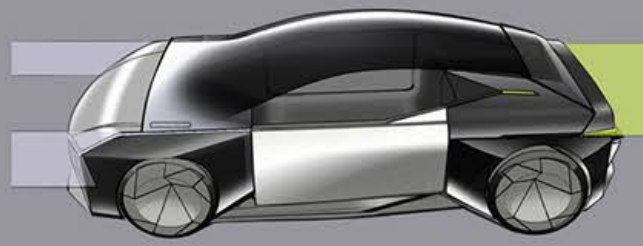
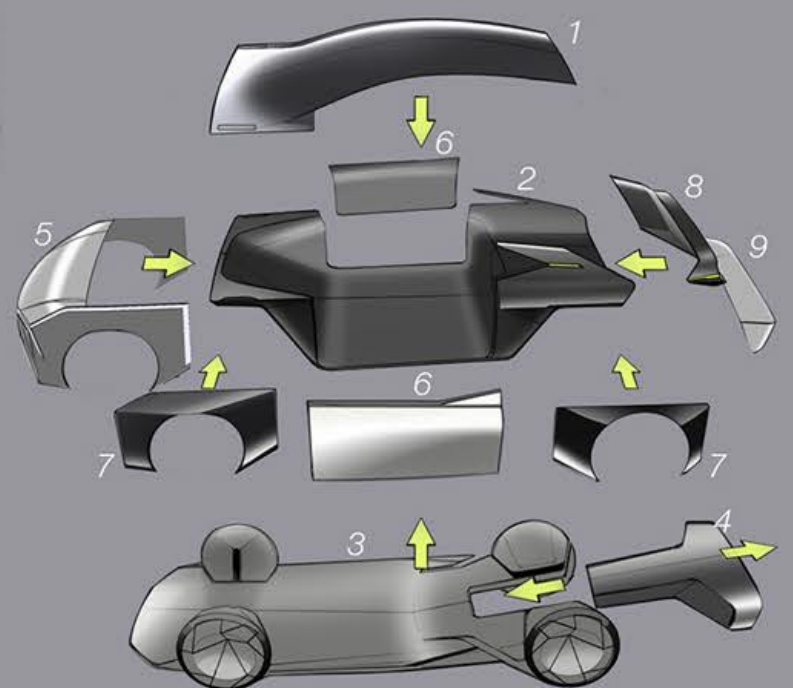
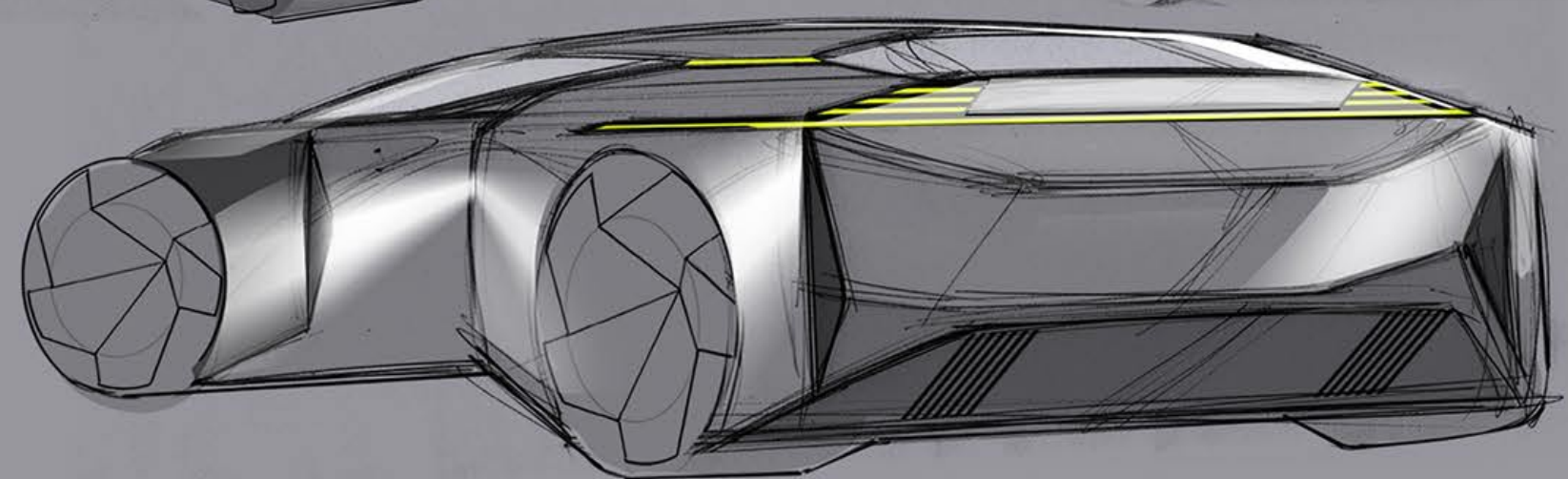

- 1 DOME
- 2 COMPOSITE TUB
- 3 "SKATEBOARD" PLATFORM
- 4 BATTERY PACK
- 5 FRONT END
- 6 DOORS
- 7 FENDERS
- 8 TRUNK
- 9 BUMPER

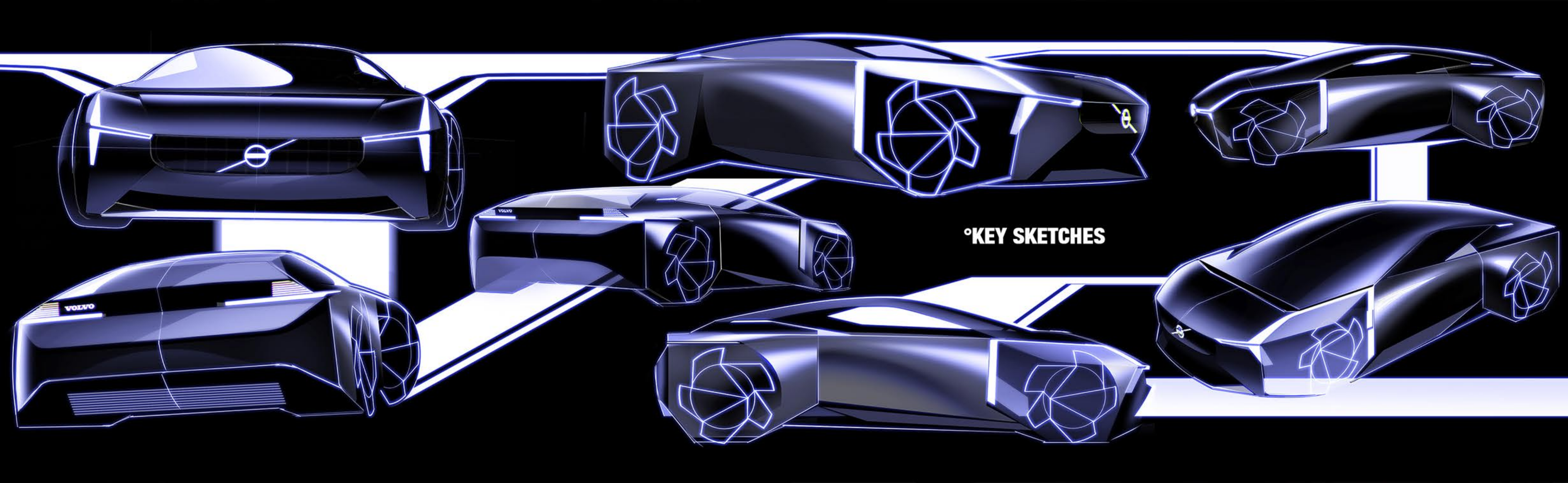

°KEY SKETCHES

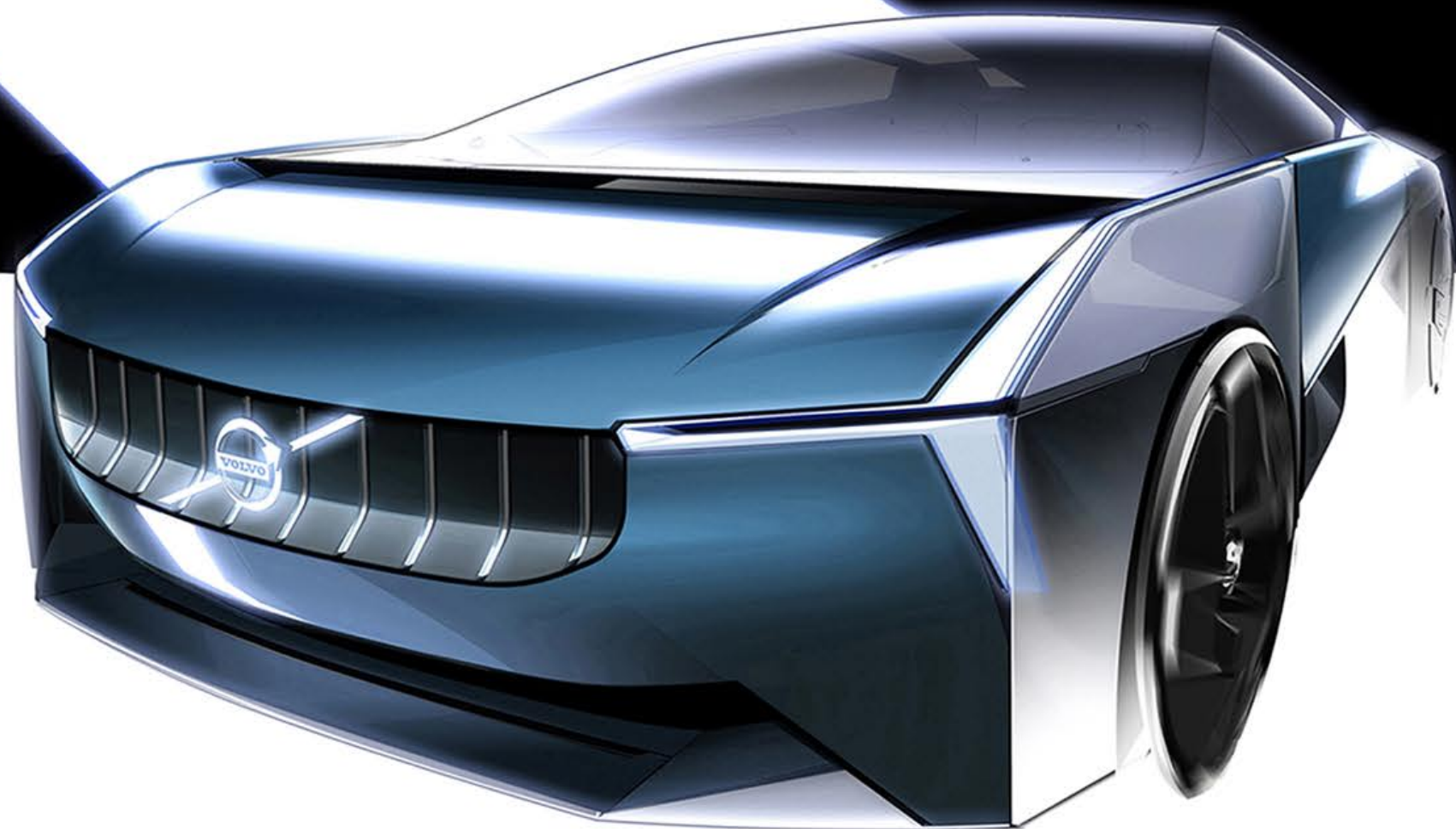

STRICKING-YET-SIMPLE *silhouette*
merges **SOLIDITY** *and* **FLOWING** *lines*

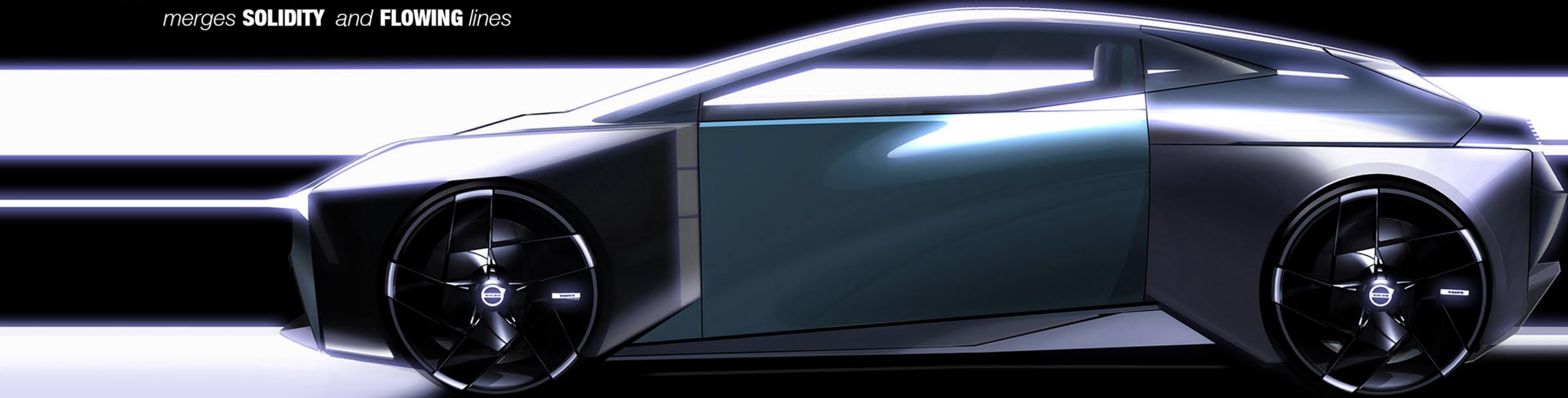

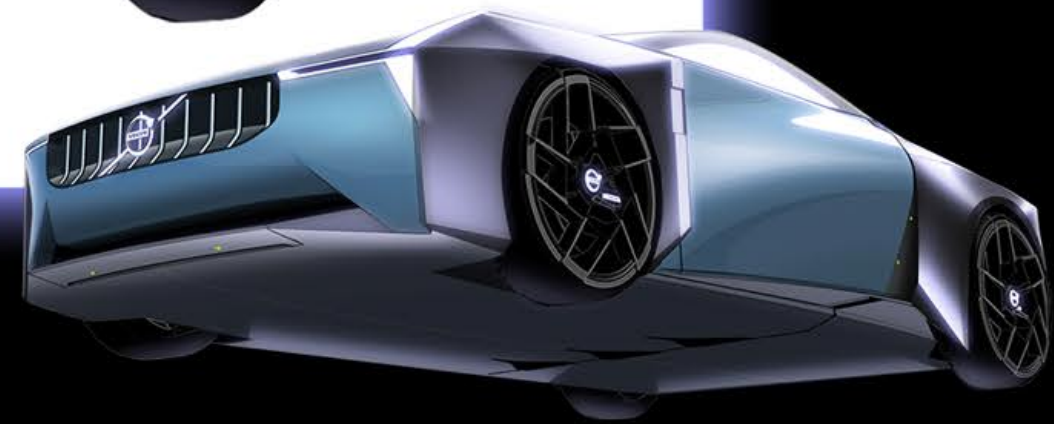
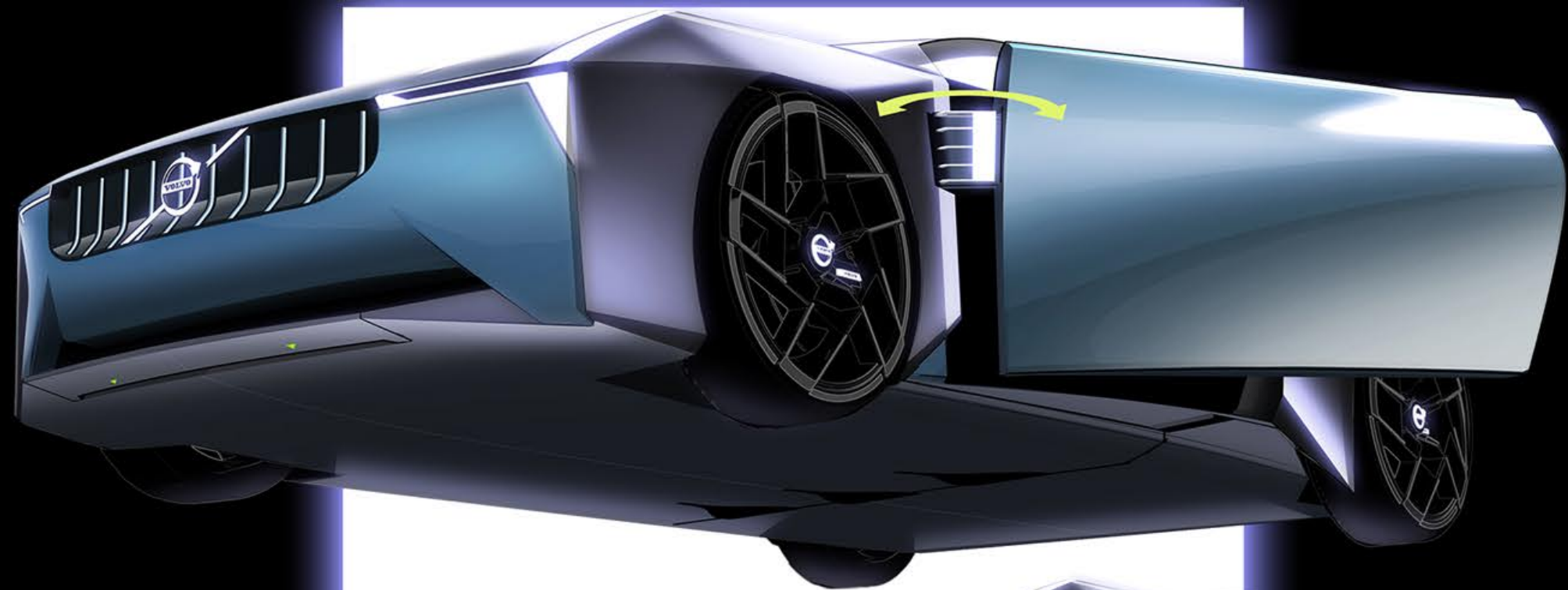
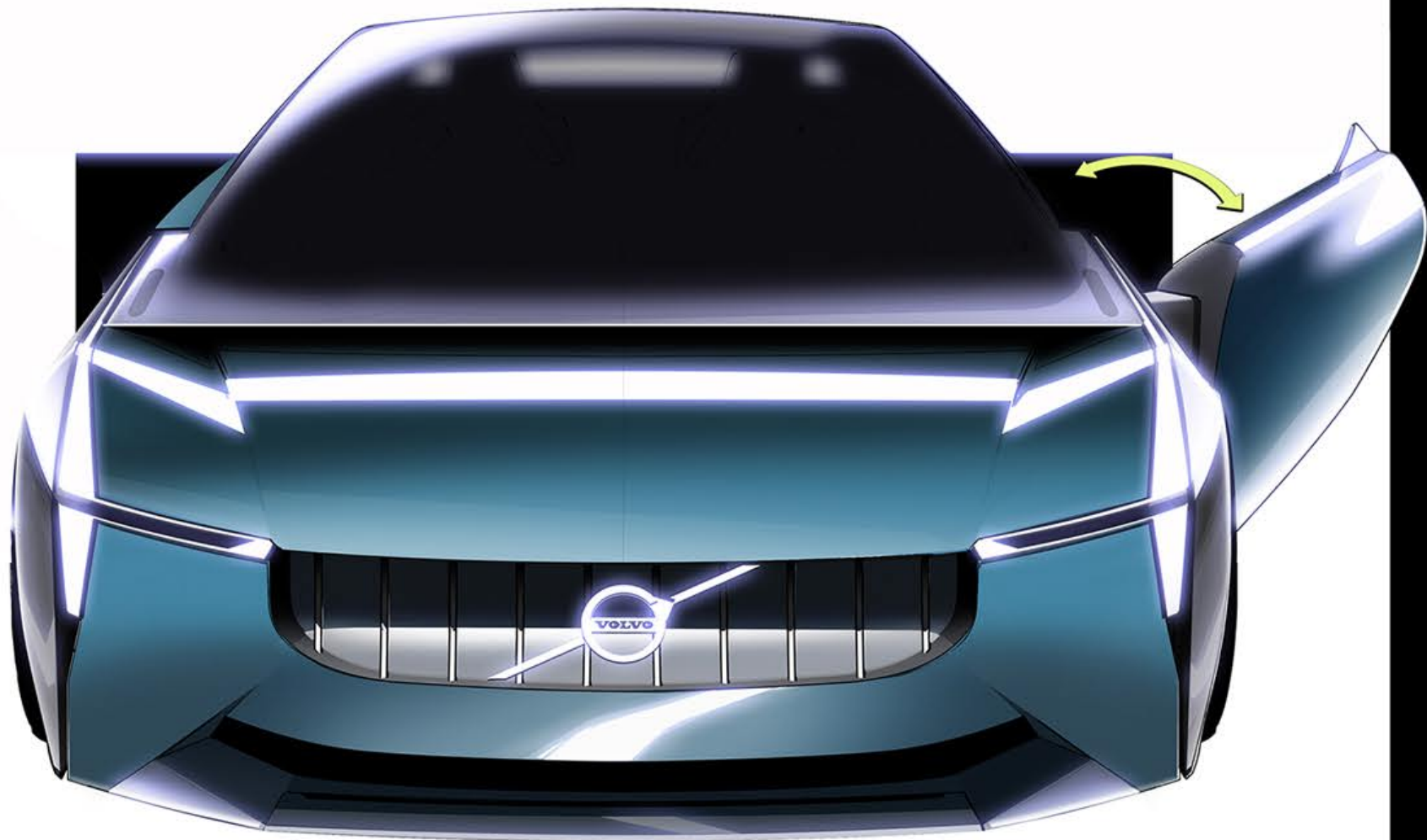

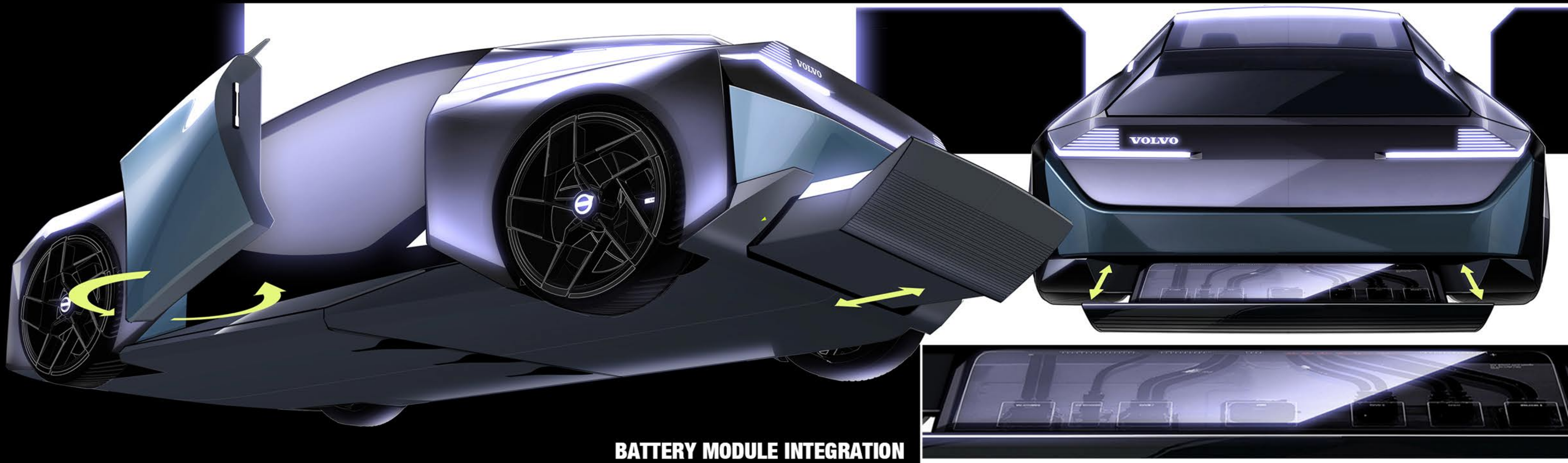

BATTERY MODULE INTEGRATION

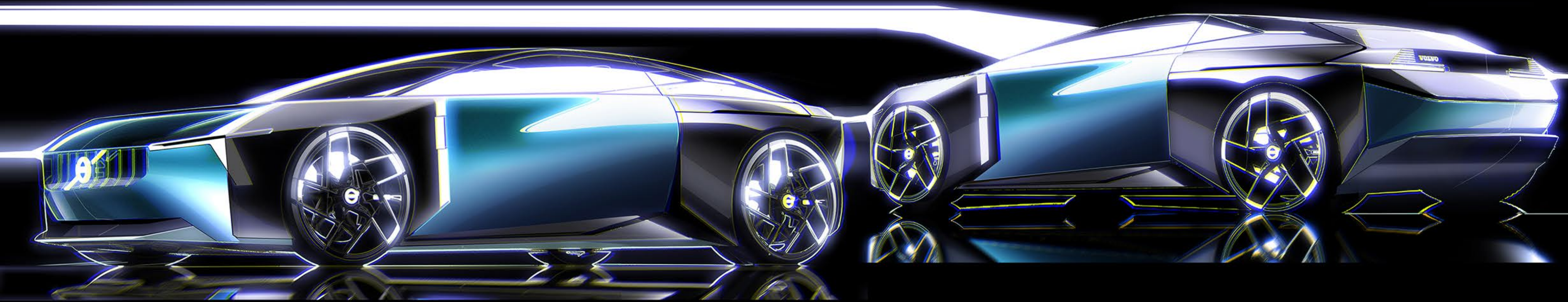

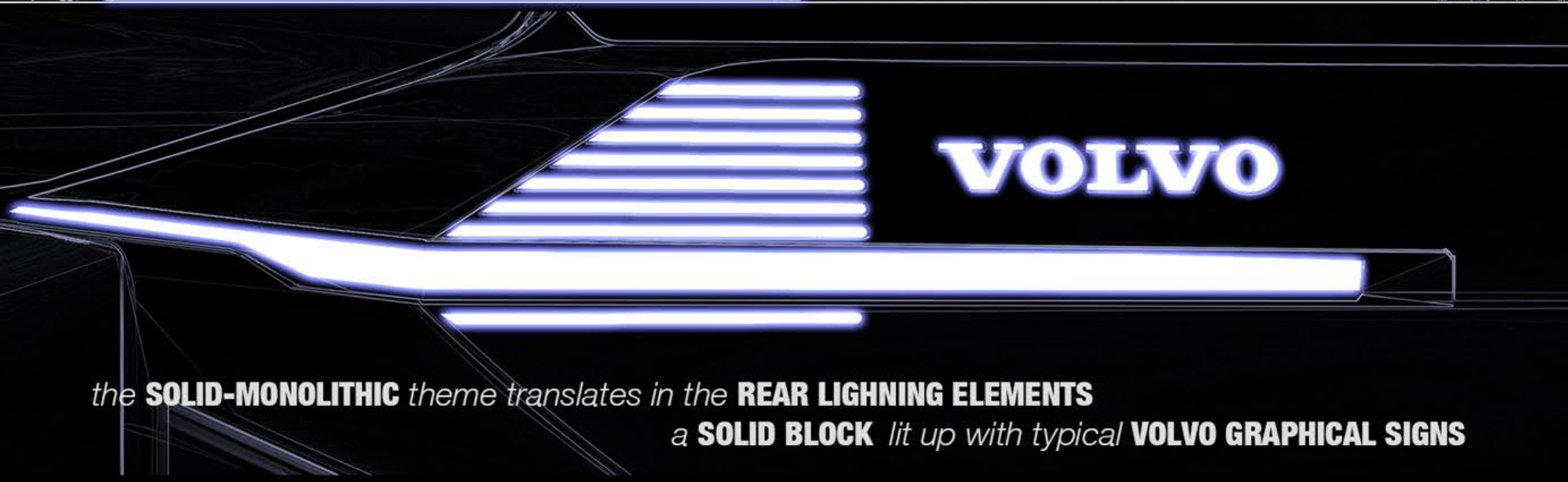
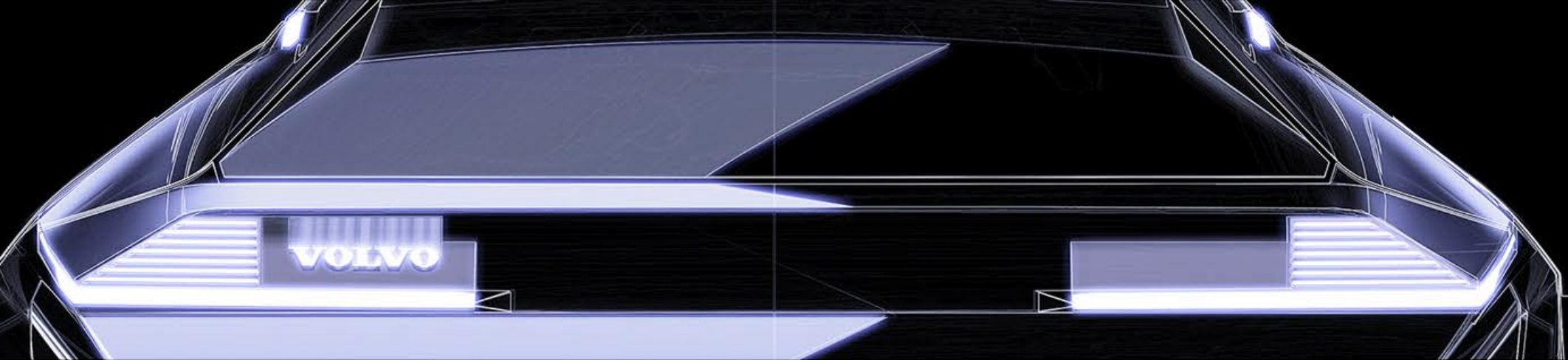

*the **SOLID-MONOLITHIC** theme translates in the **REAR LIGHTING ELEMENTS**
a **SOLID BLOCK** lit up with typical **VOLVO GRAPHICAL SIGNS***

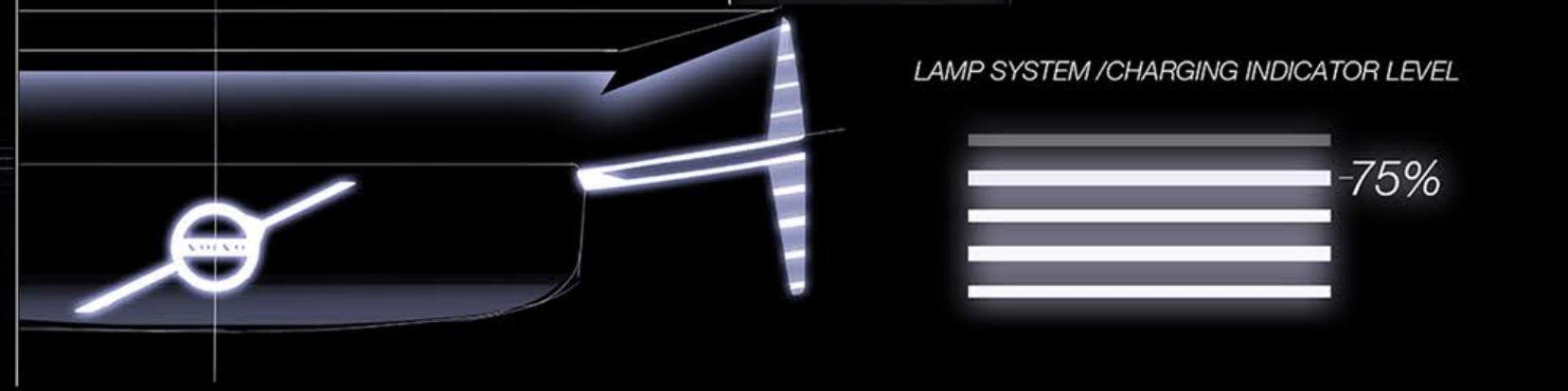
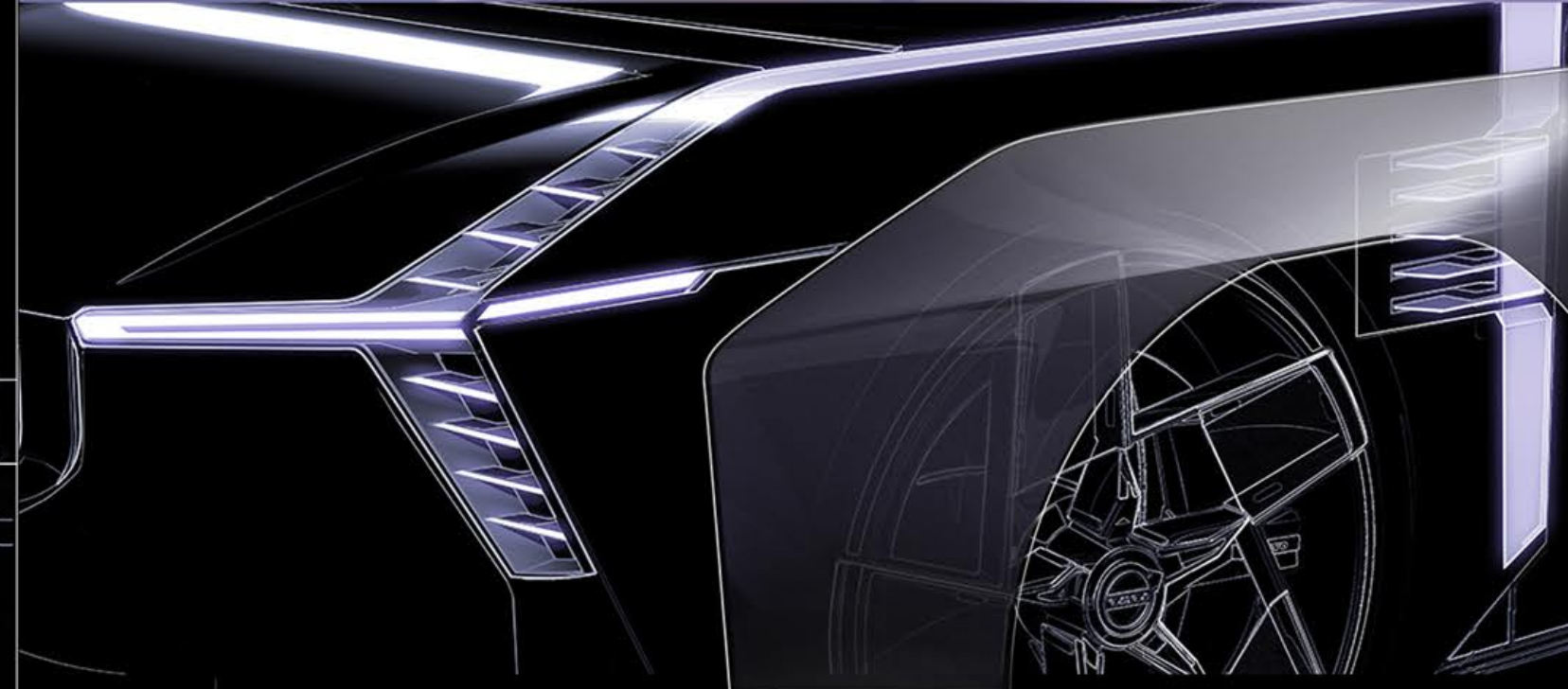

LAMP SYSTEM /CHARGING INDICATOR LEVEL



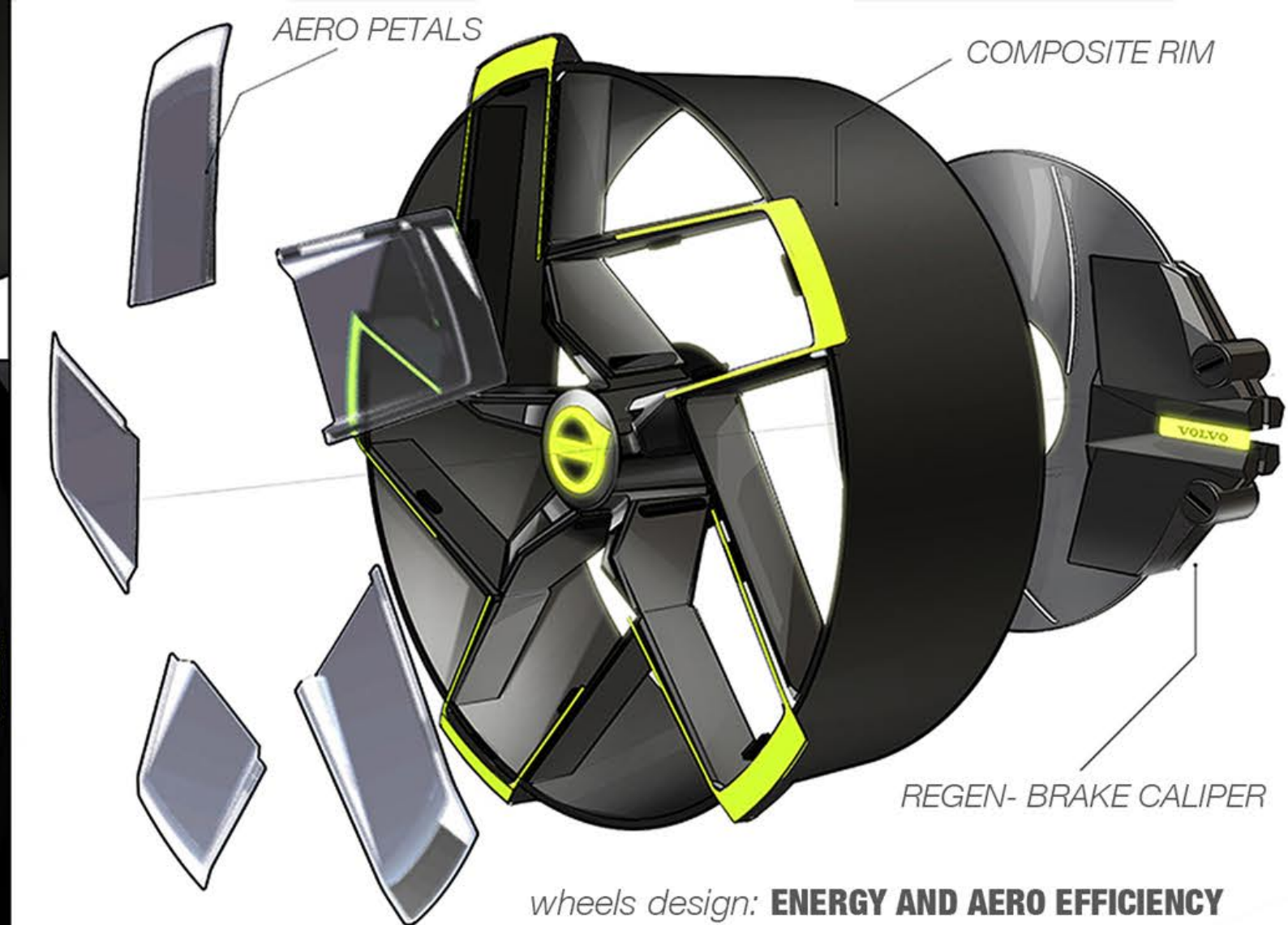
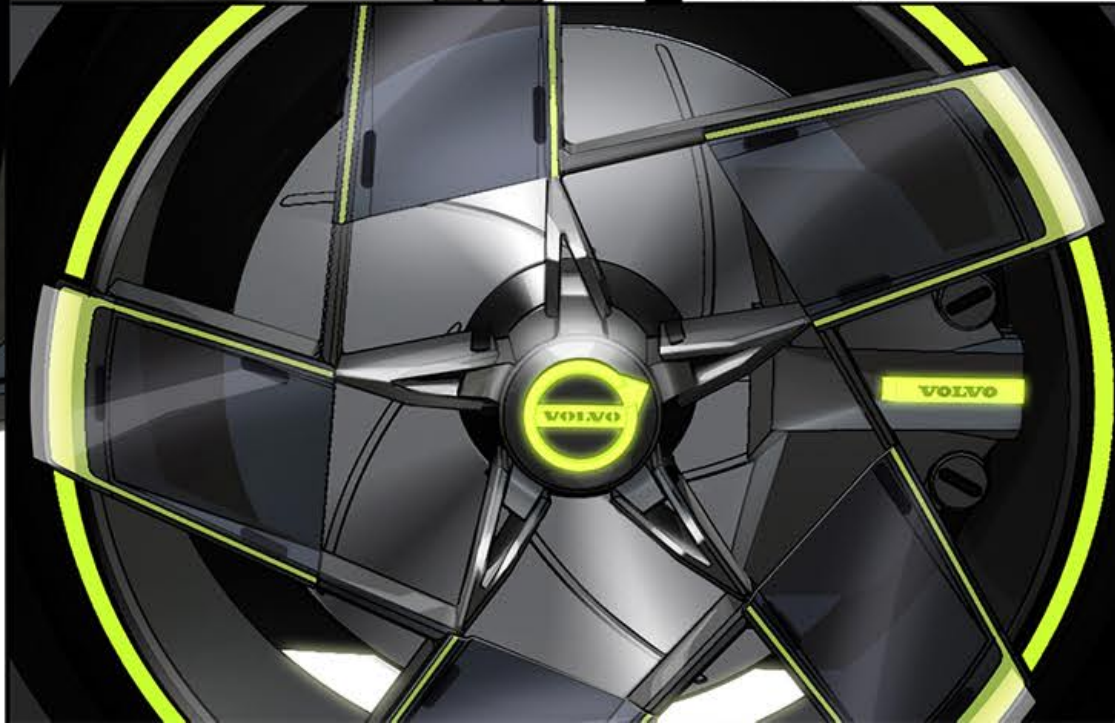

wheels design: **ENERGY AND AERO EFFICIENCY**



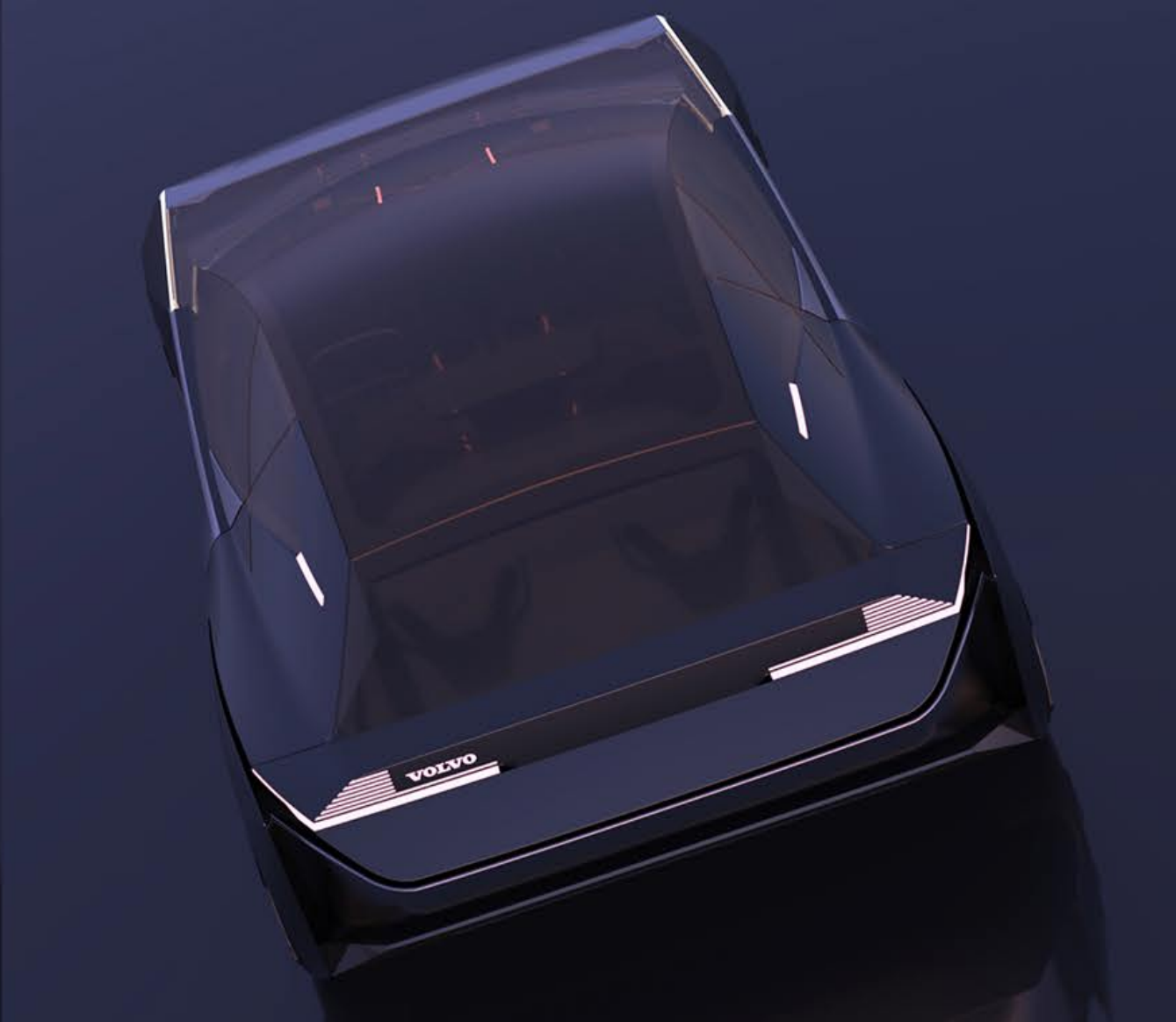





MISCELLANEA

* Mx-20 wHat If ElecTric was FUN!?

quick proposal for a fun YET electric CUV

mazda



創
味

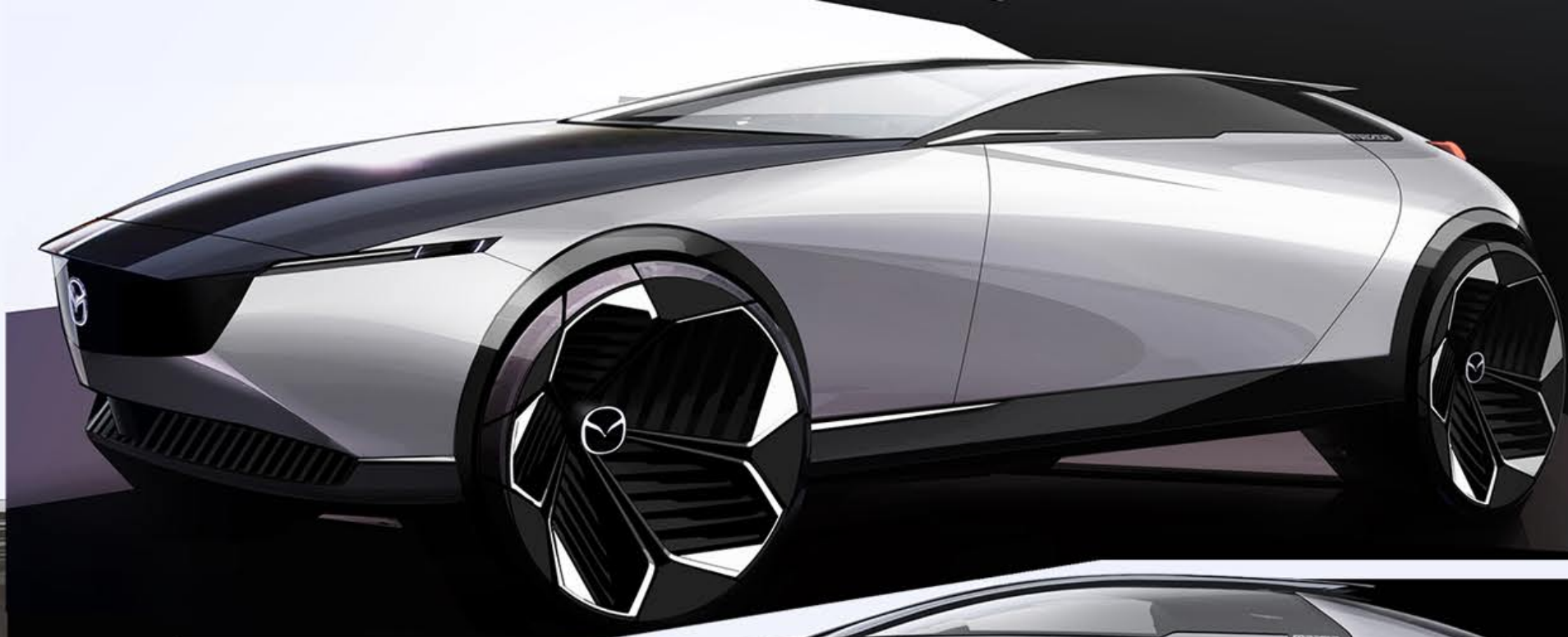



...Fantasizing about Alfas

THE MORE STRUCTURED SHIELD-SHAPED GRILL IS REMINISCENT OF THOSE FOUND ON THE GLORIOUS ALFAS FROM THE 60S

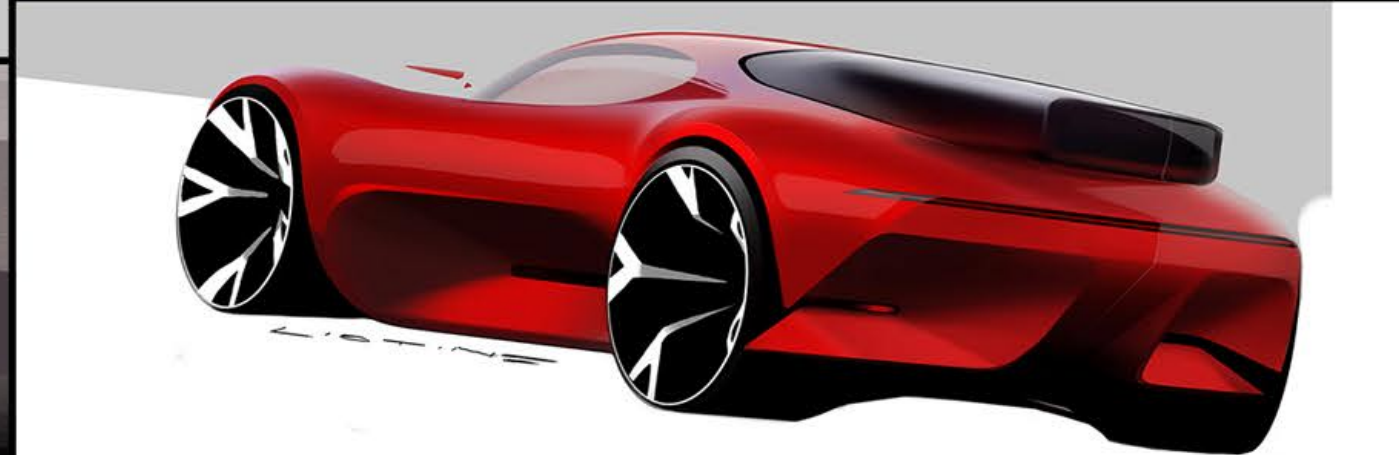
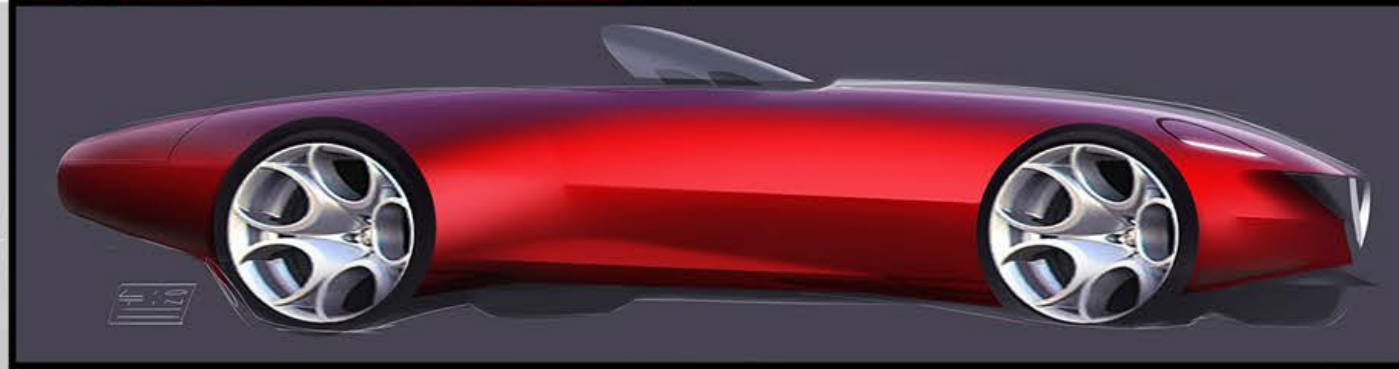

SOFT BODYTYPE AND PRODUCT-ISH FEATURES. THE OBLONG BACK WINDOW HAS BOTH AERODINAMIC FUNCTION AND WORK AS STORAGE FOR SKIS AND BOARDS.

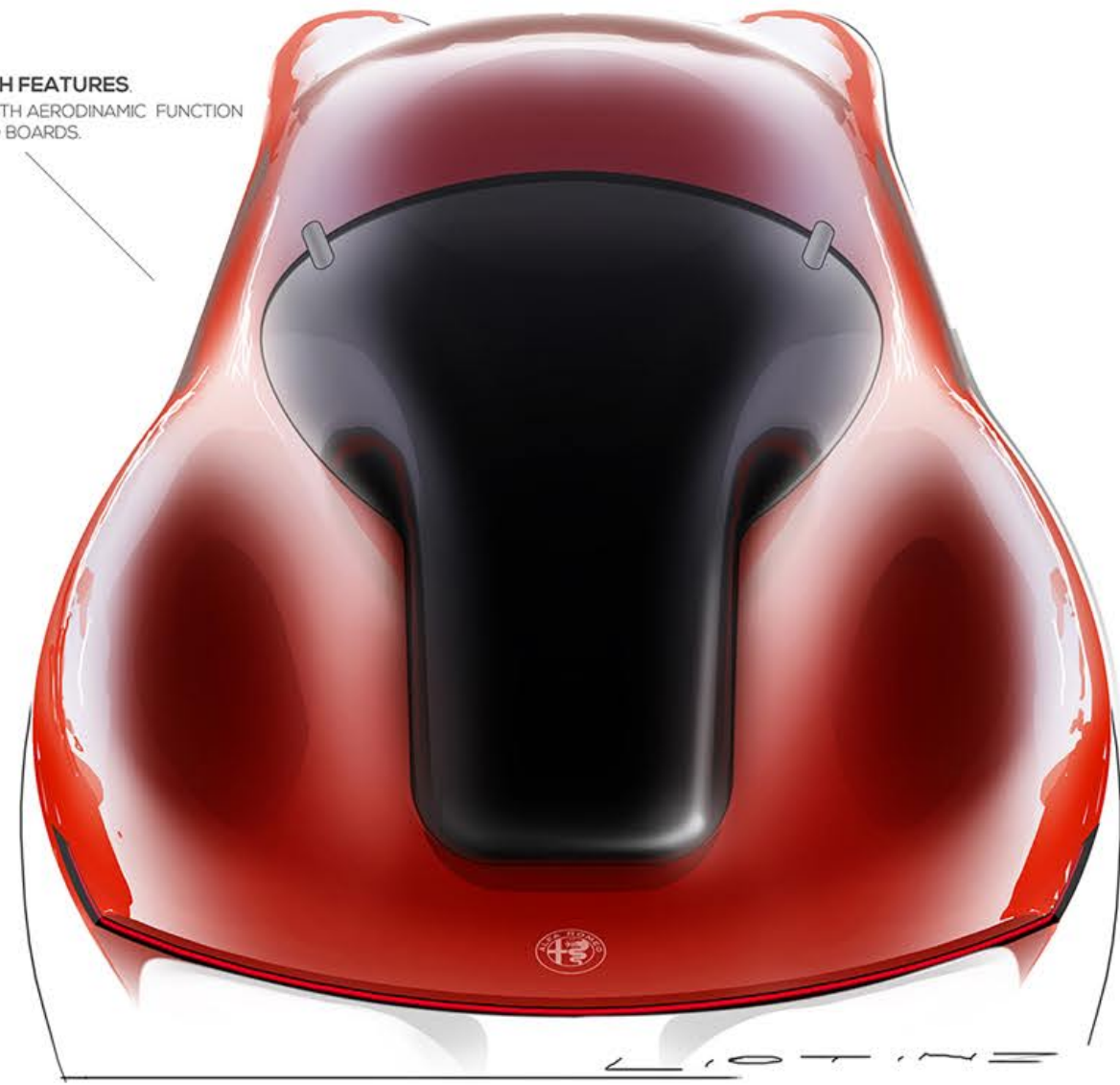

*Alfa Romeo
Visconti*

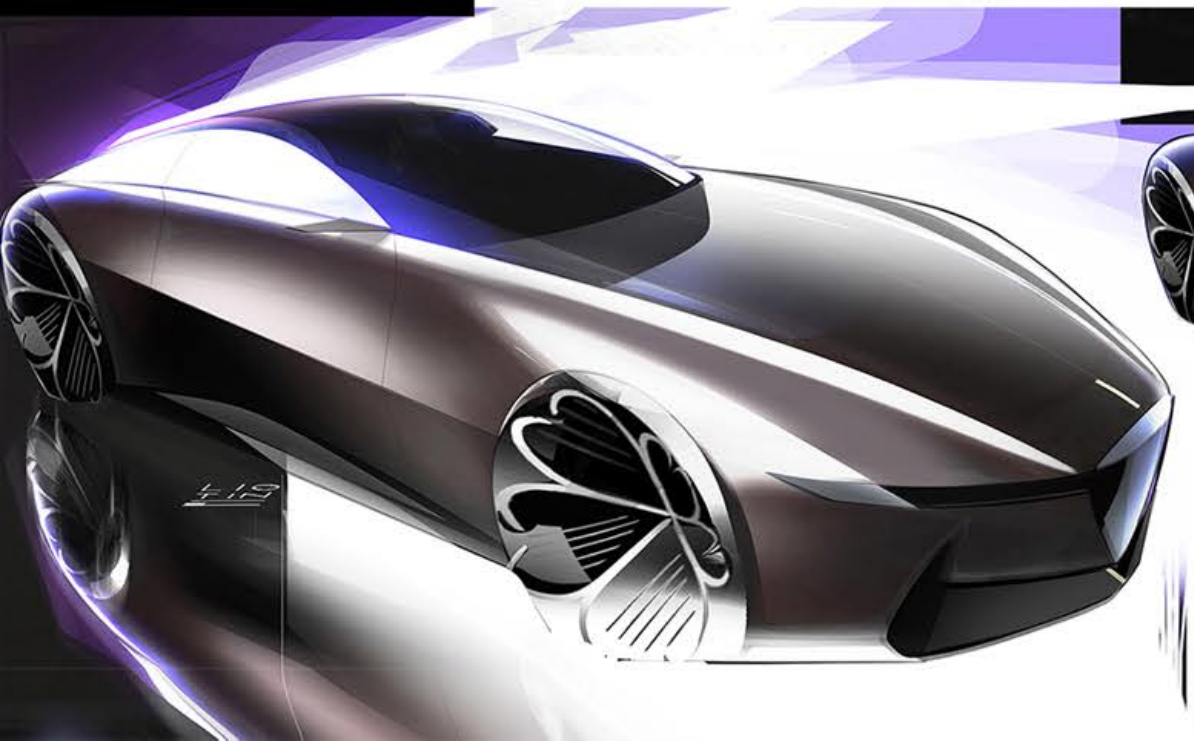
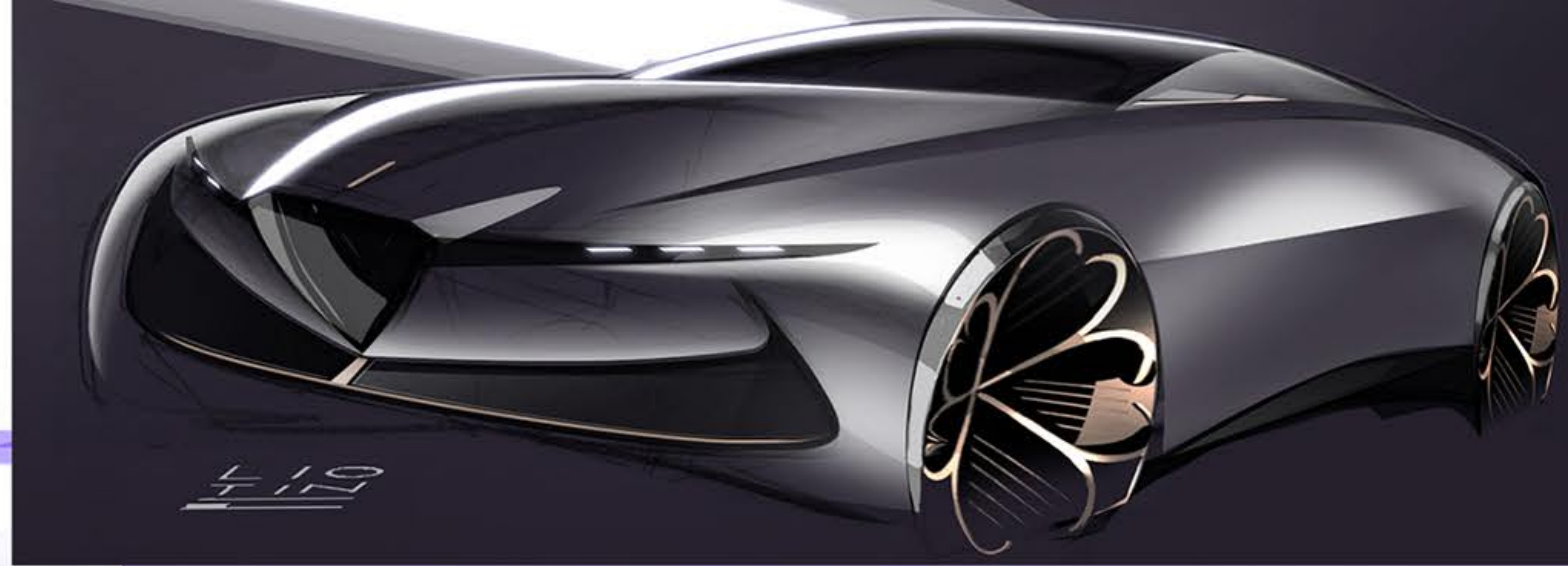
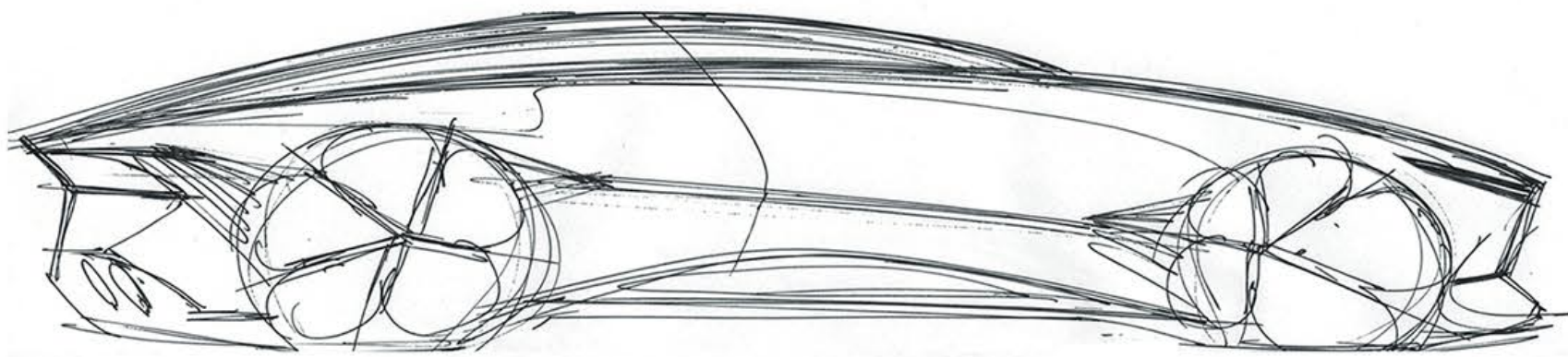

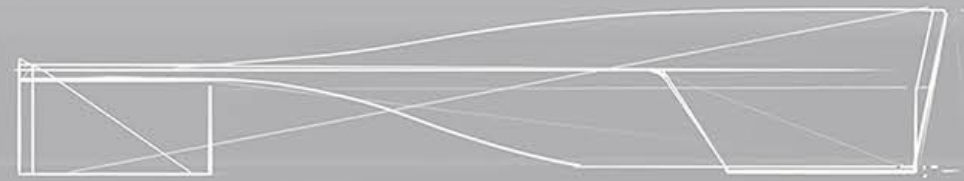
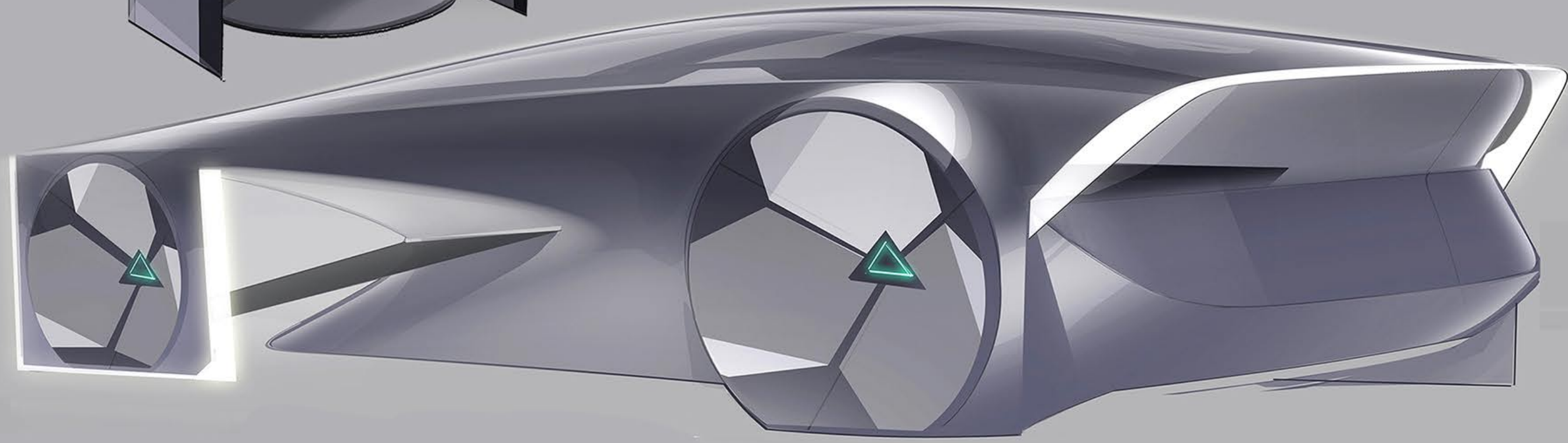
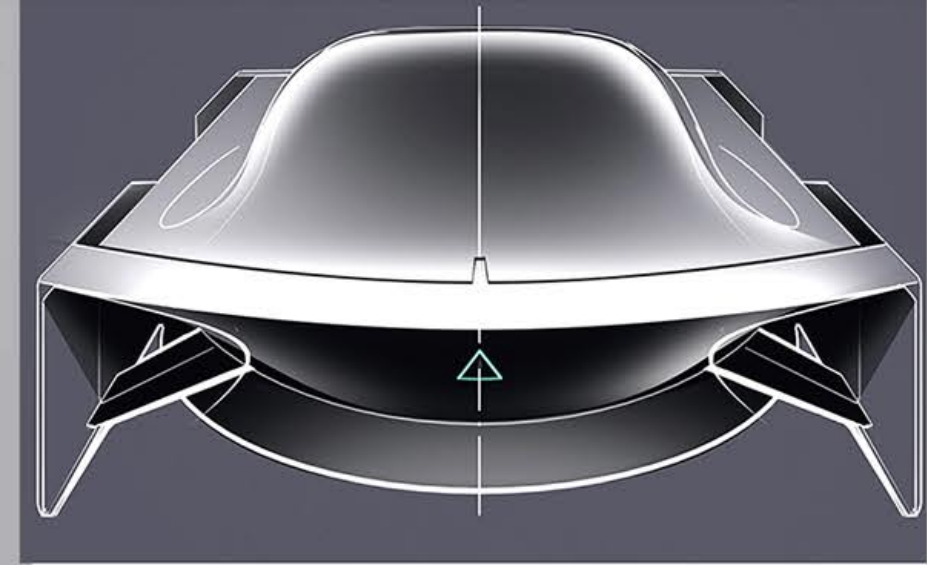
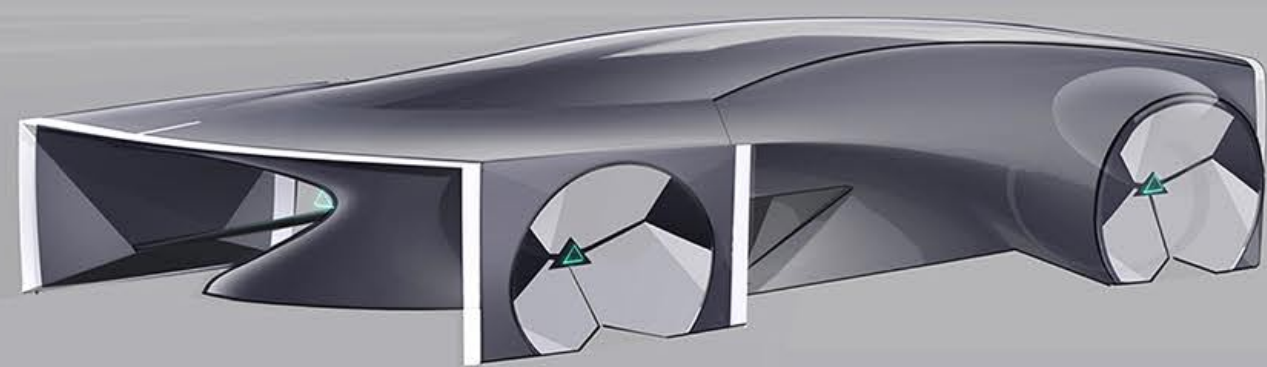
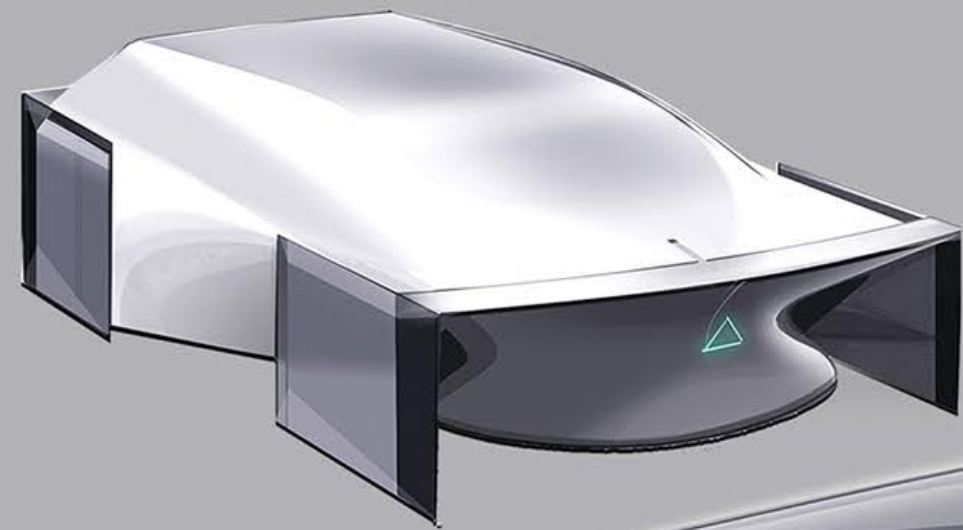



*** KEY SKETCHES**

THE MAIN THEME IS THE LIGHTWEIGHT LOOK OF THE VEHICLE. THE **HOLLOW BODY** IS FUSED WITH THE **INTEGRATED HELMET STRUCTURE** WHICH ALLOW TO MAINTAIN AN OPEN "BARCETTA" BODYTYPE WHILE PROVIDING MORE SAFETY TO THE DRIVER.

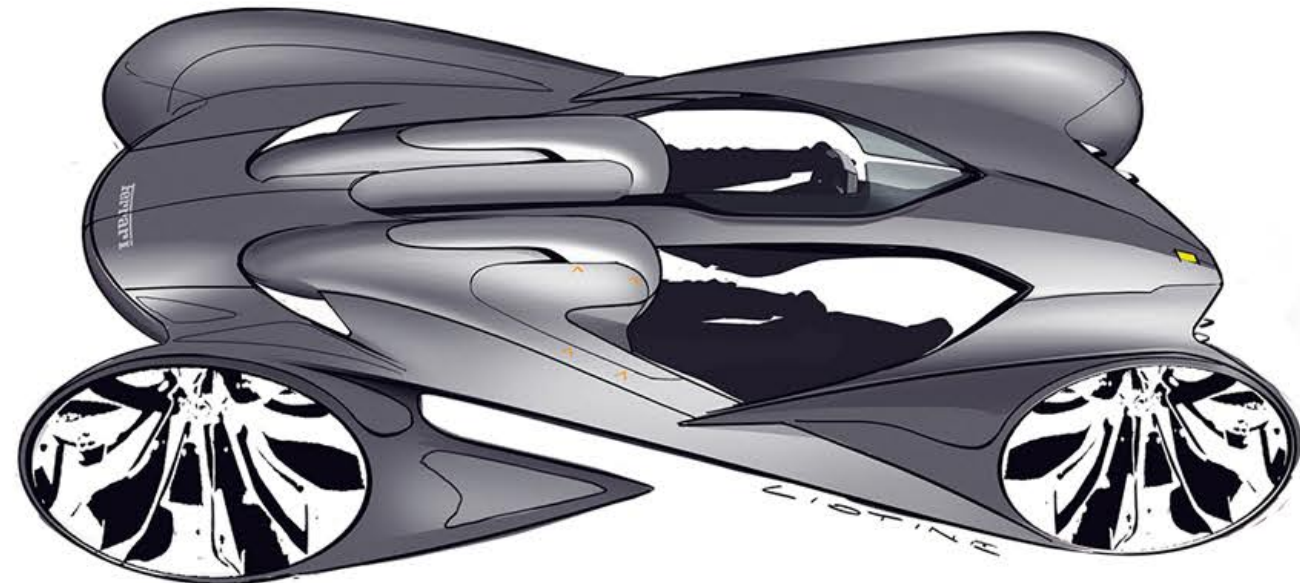
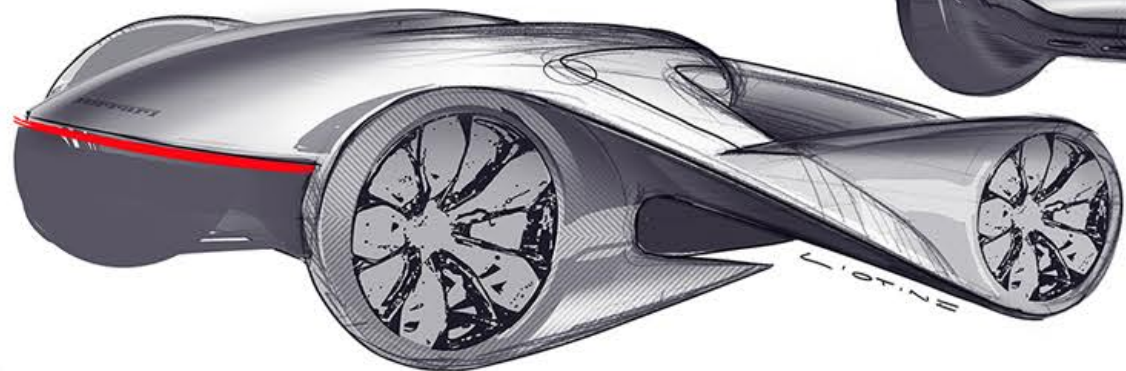

*** RACING AIR**

THE HELMET **ENHANCE** THE SAFETY OF THE VEHICLE WHILE PROVIDING USEFUL INFORMATIONS TO THE DRIVER

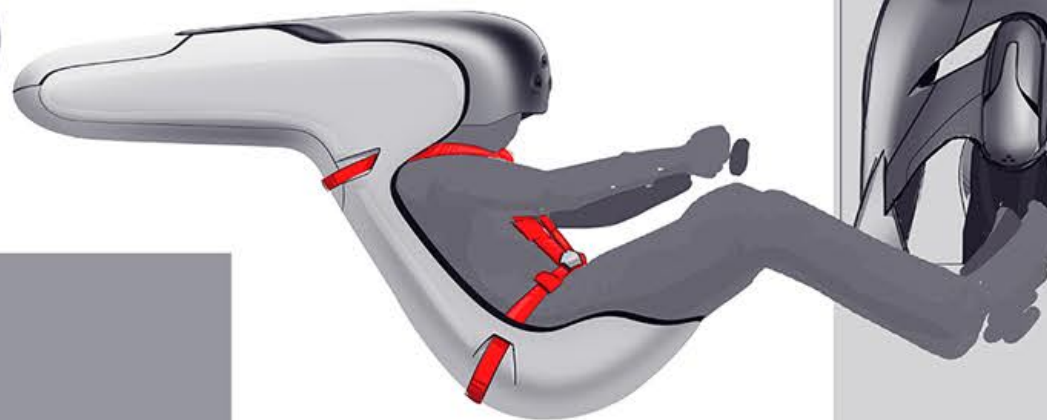

"I think of myself as constantly realizing a childhood dream."
Enzo Ferrari

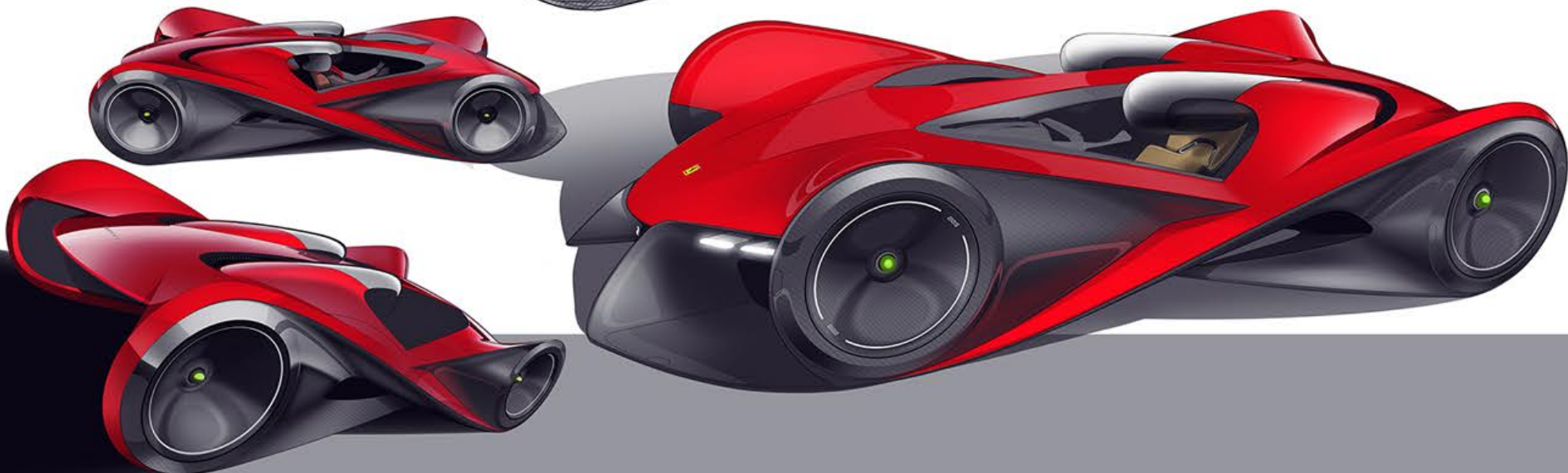

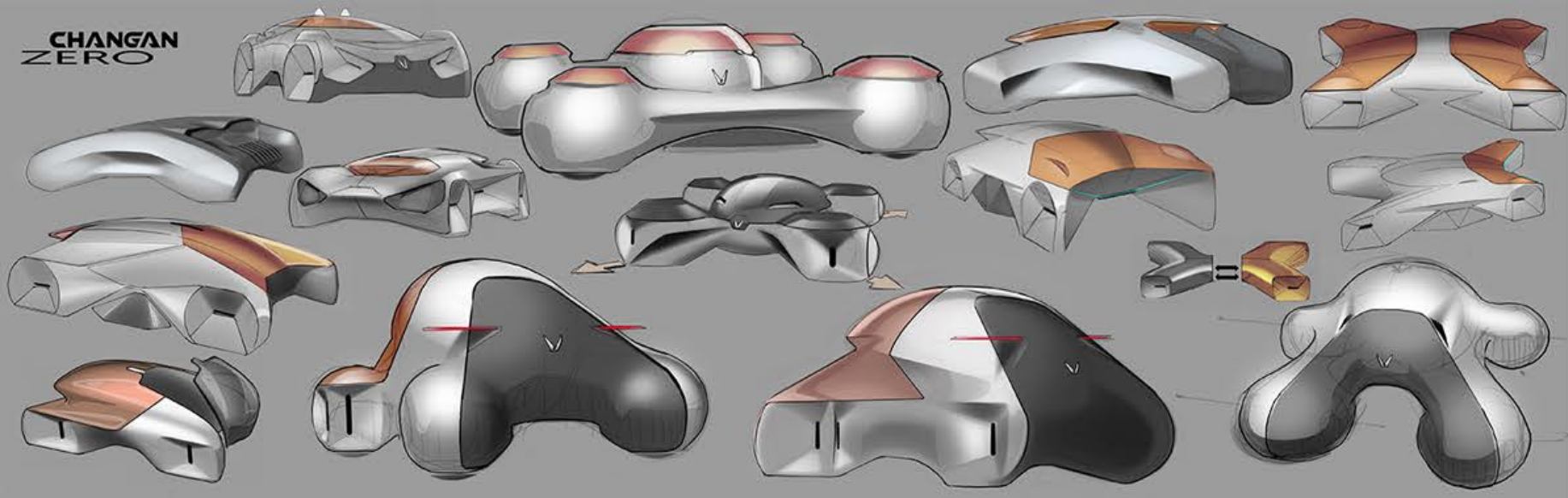

personal mobility vehicle and flagship sporty sedan studies

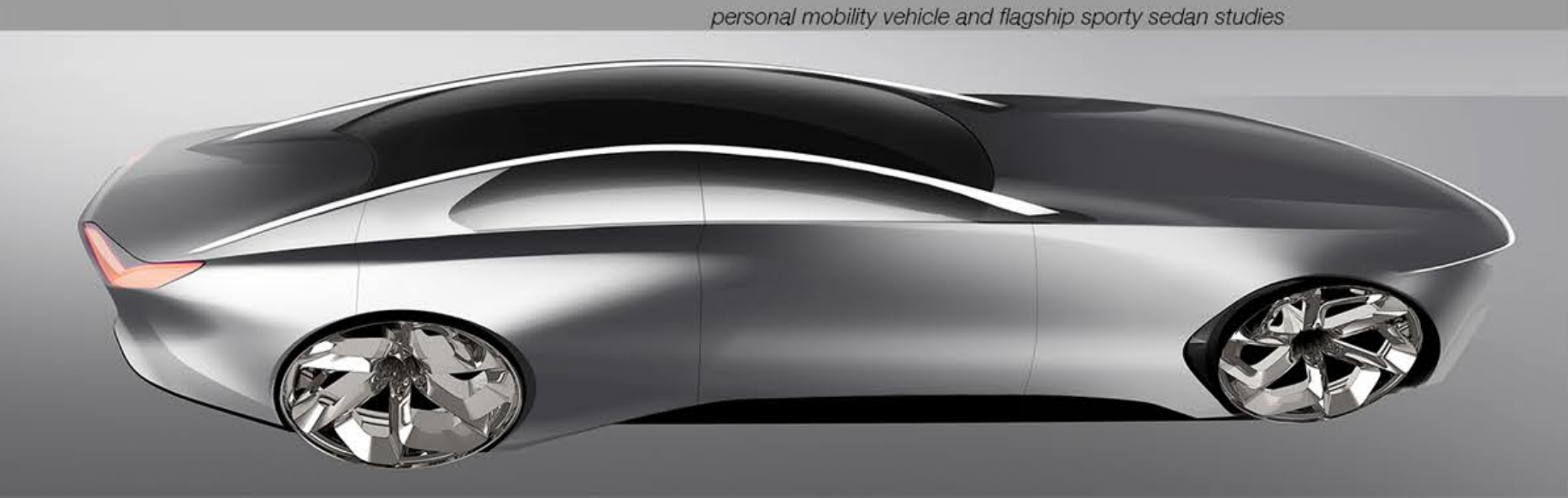
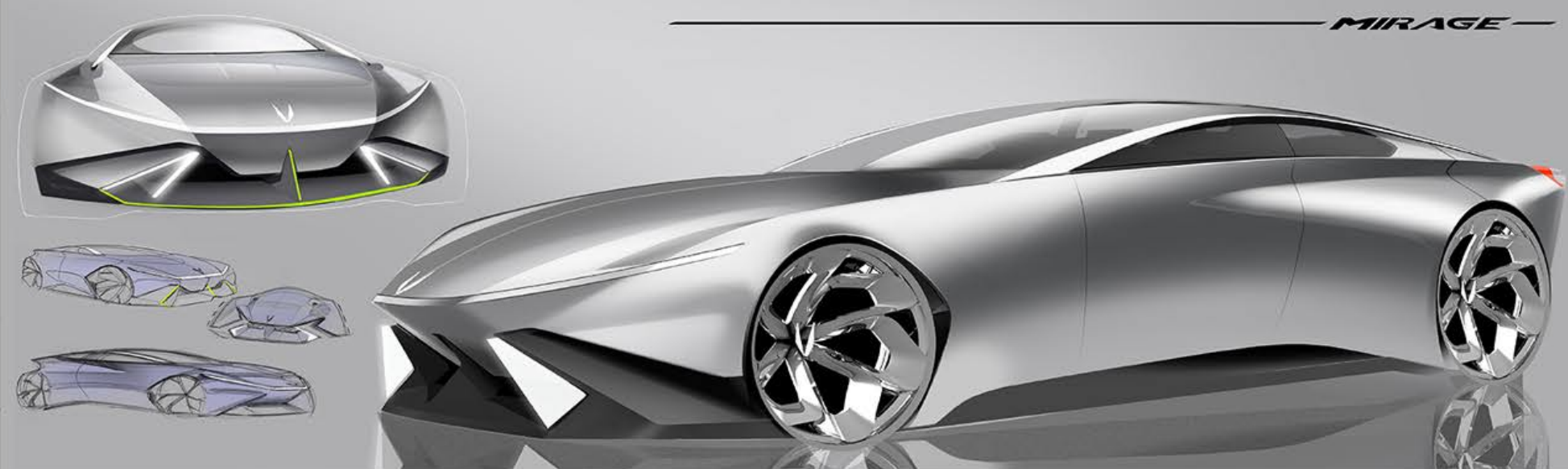

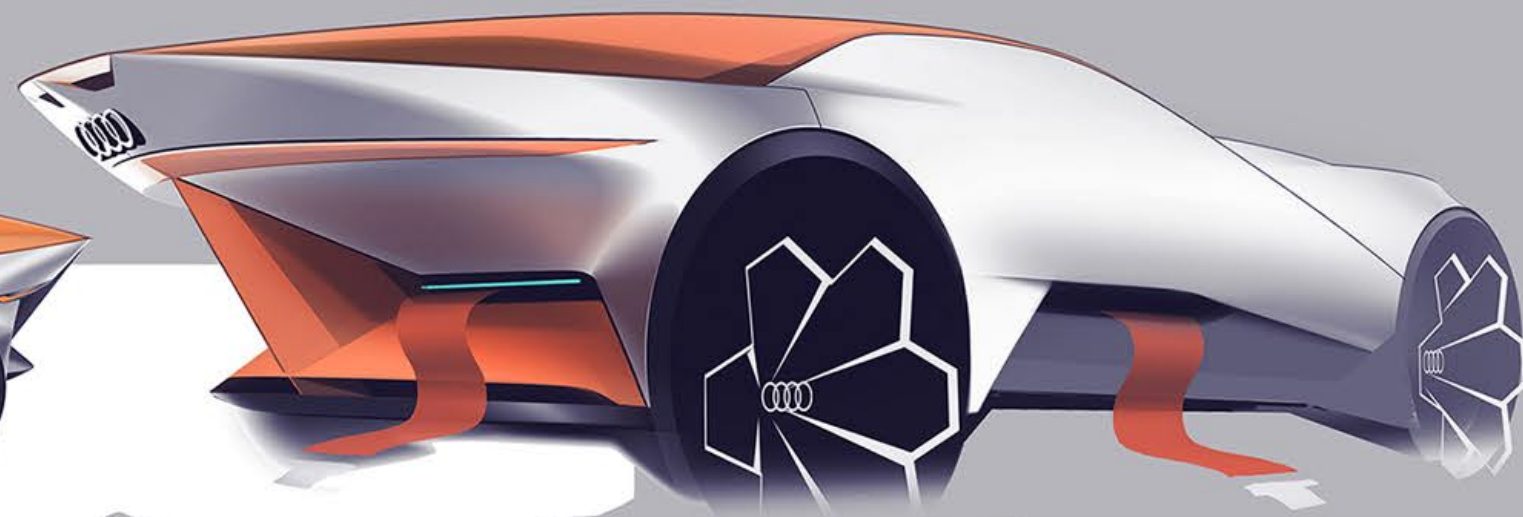
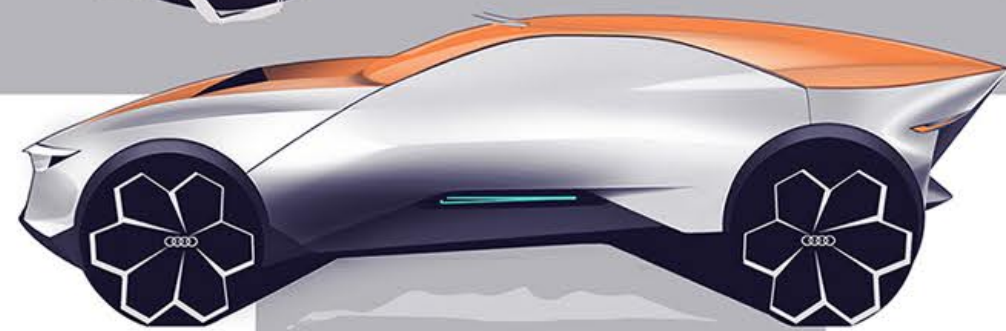
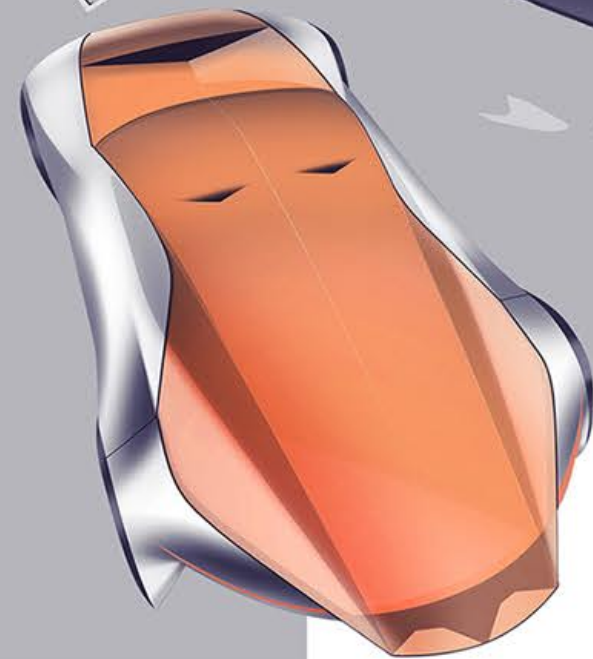
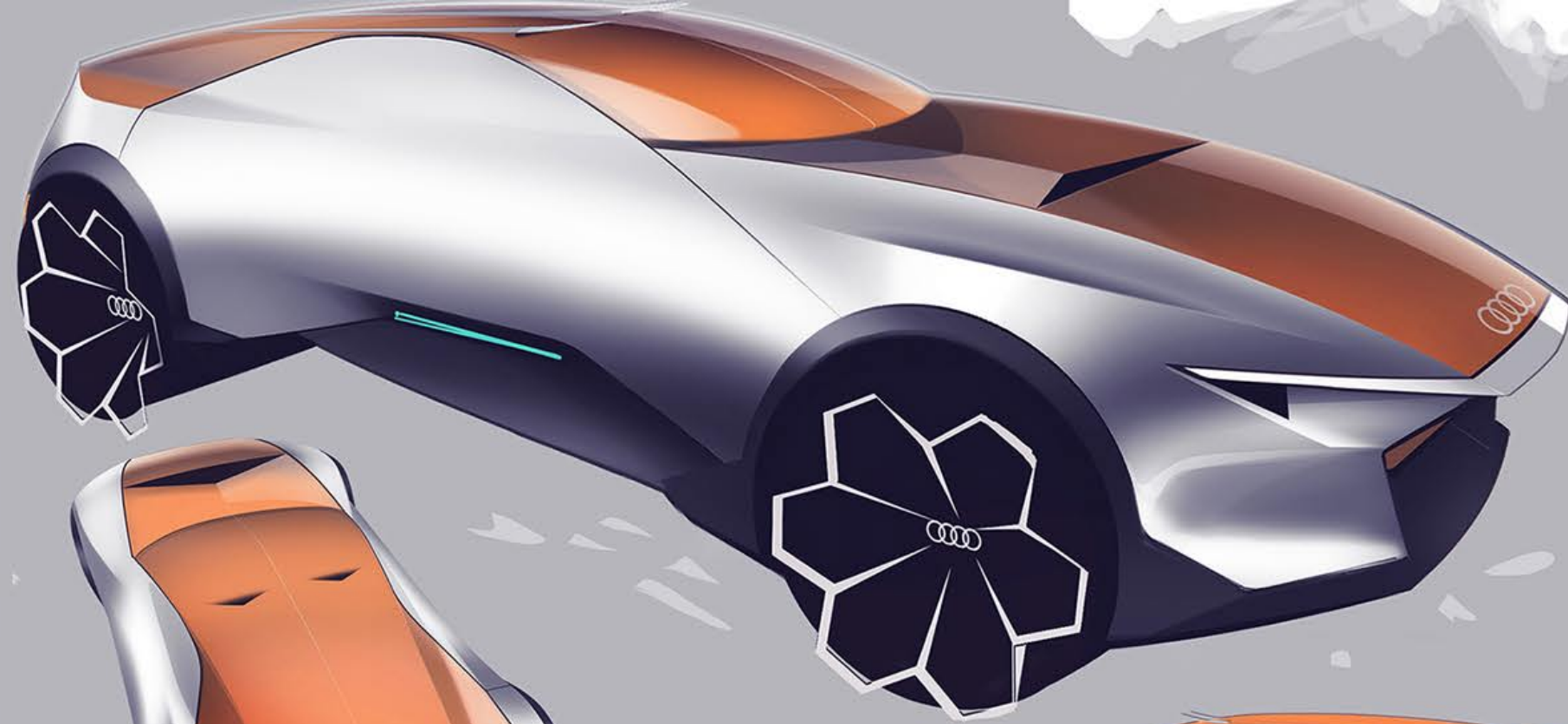

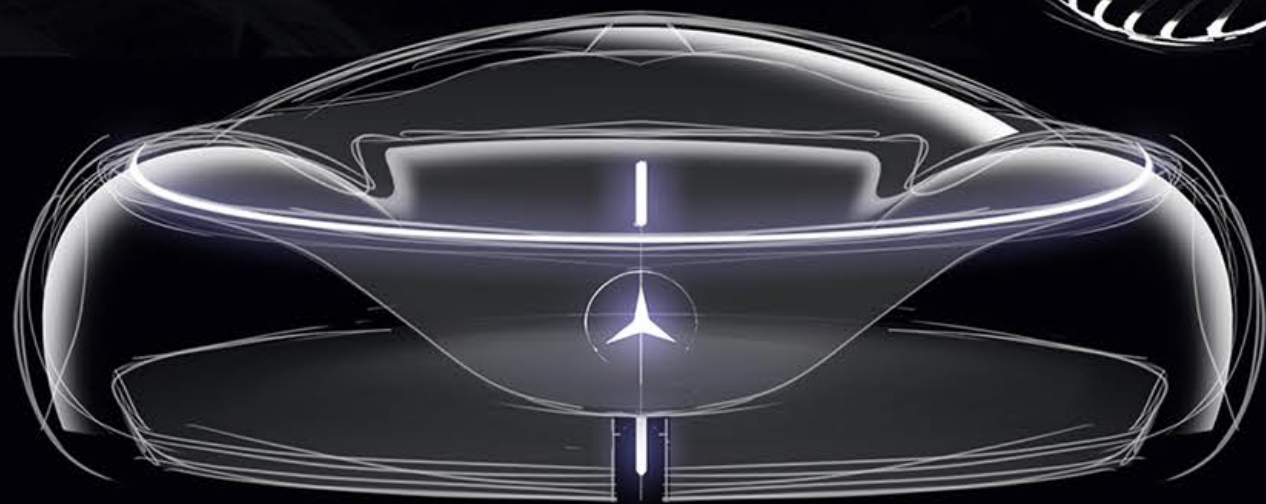
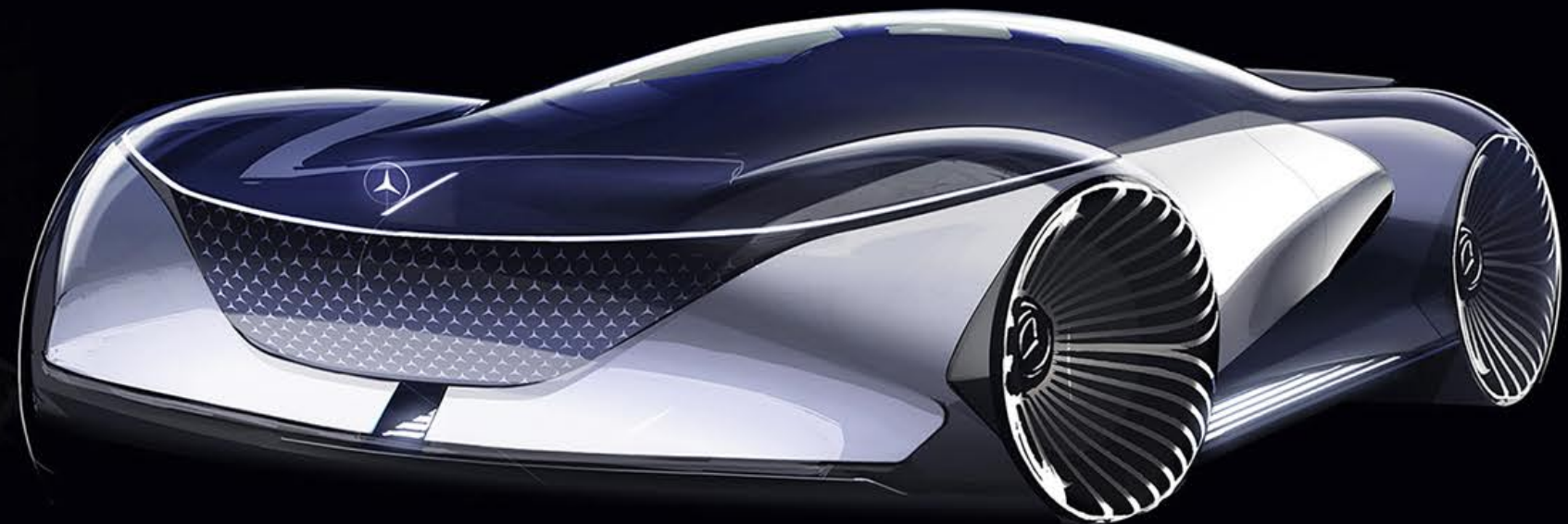
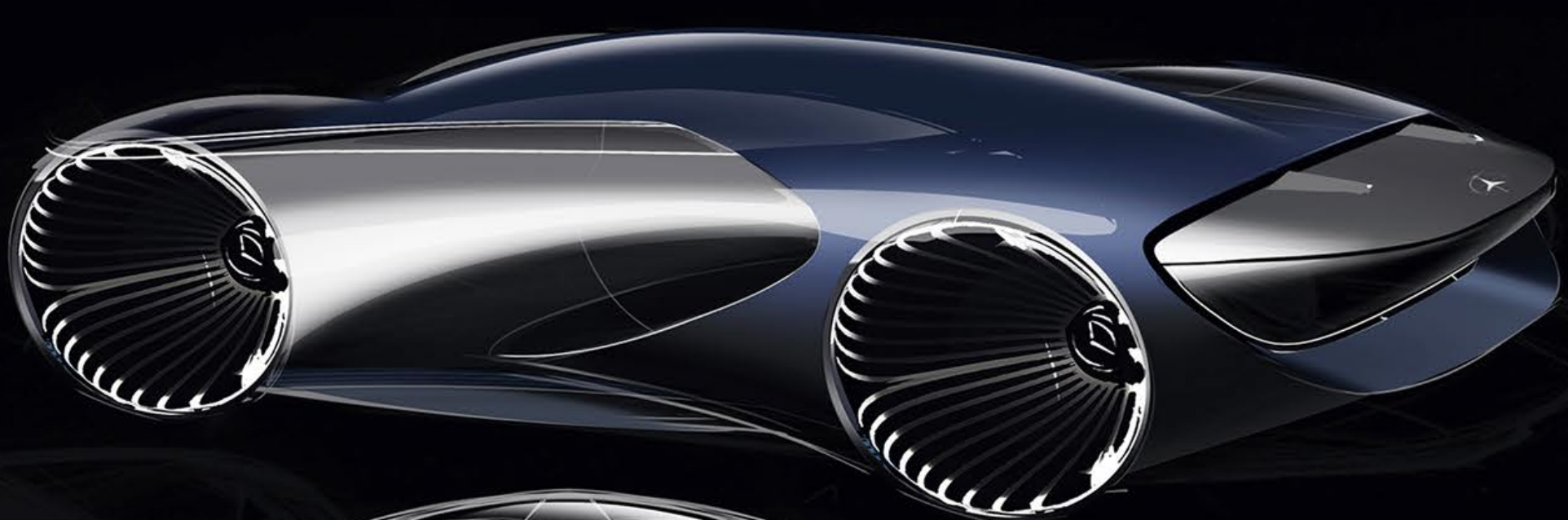

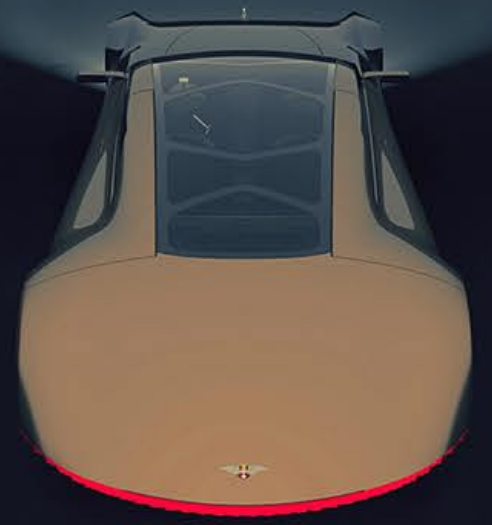

THE DUBONNET IS MY PERSONAL TAKE ON ONE OF THE MOST FASCINATING BRAND OF THE LATE '30S, HISPANO SUIZA, KNOWN FOR THE AERONAUTIC HERITAGE AND THE HIGH QUALITY-INNOVATIVE CONTENT OF THEIR SPORT AND SEDANS.

THIS DUBONNET TAKES HIS NAME FROM THE RACEDRIVER, AND FIGHTER PILOT ANDRE DUBONNET, ACE OF THE FRENCH STORK SQUADRON

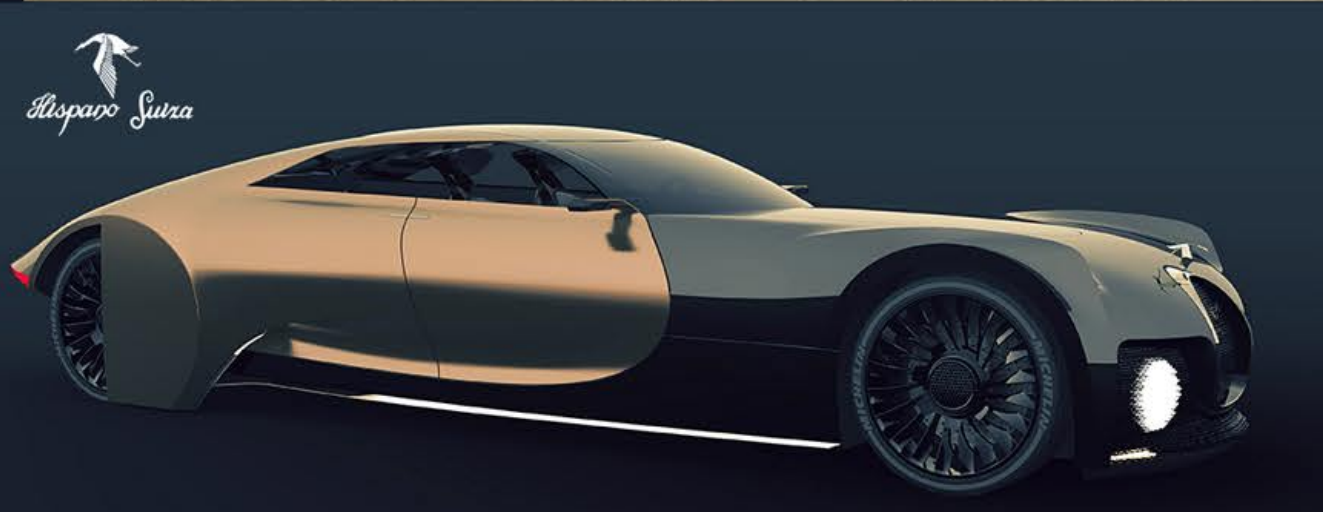

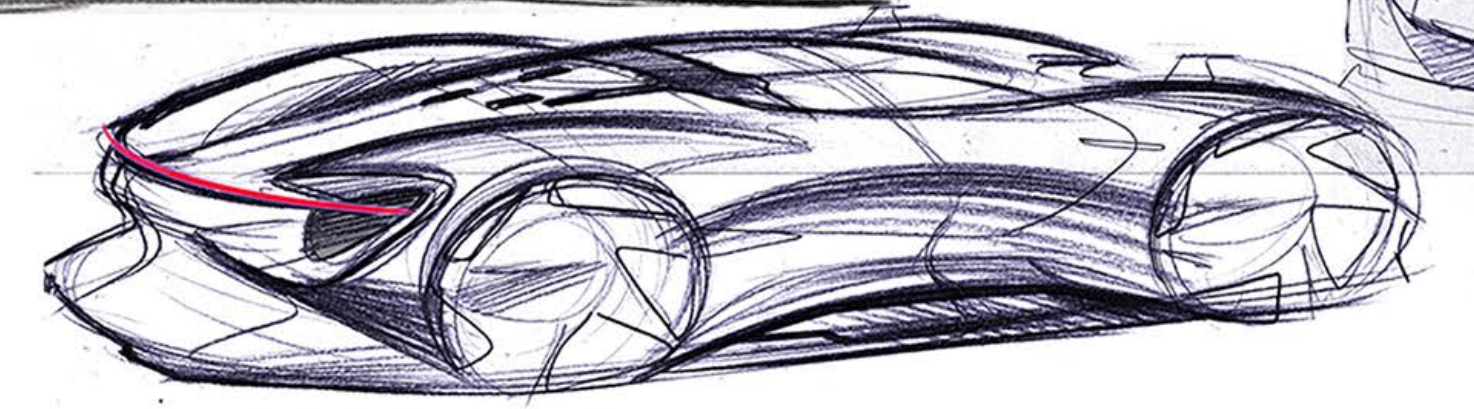
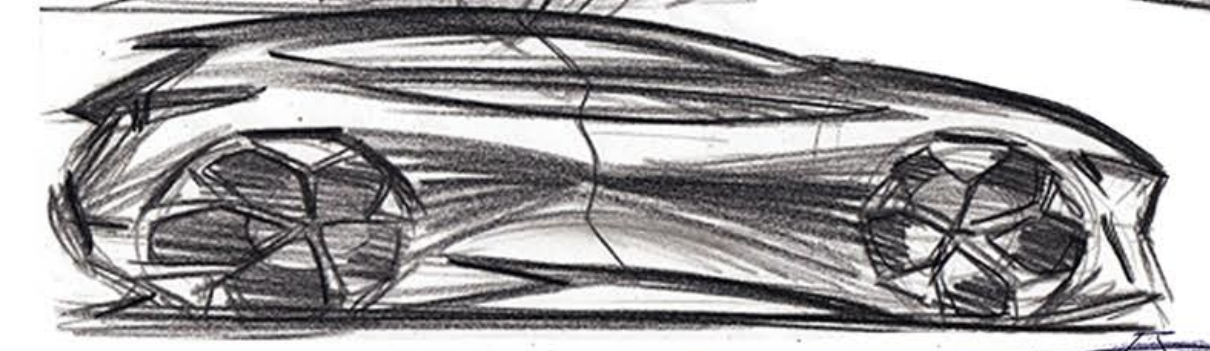
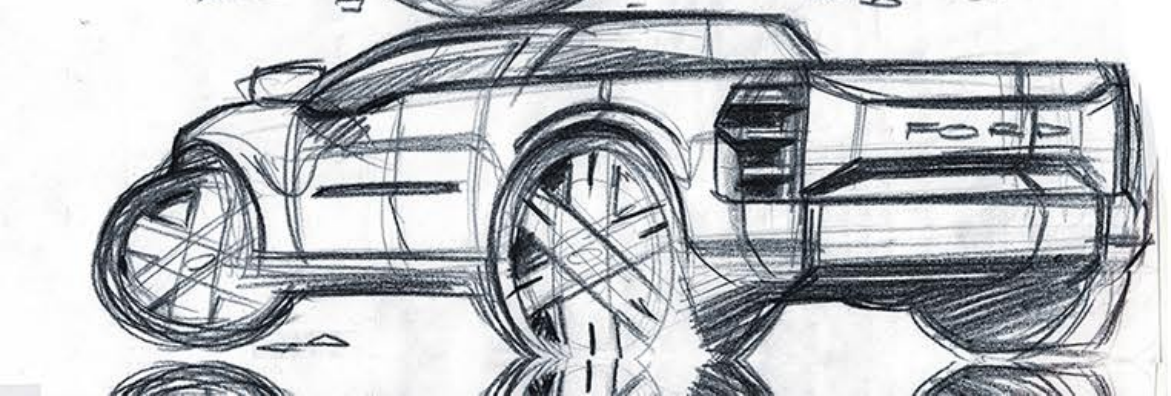
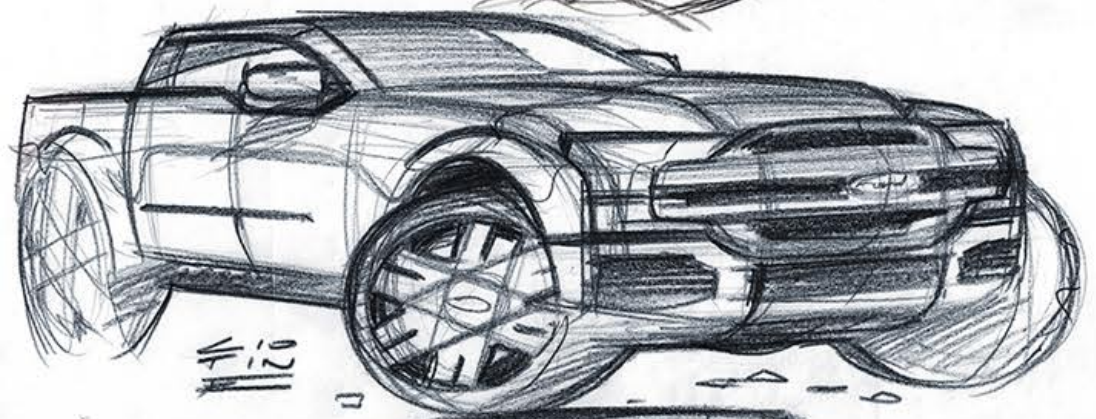

WARMUP!

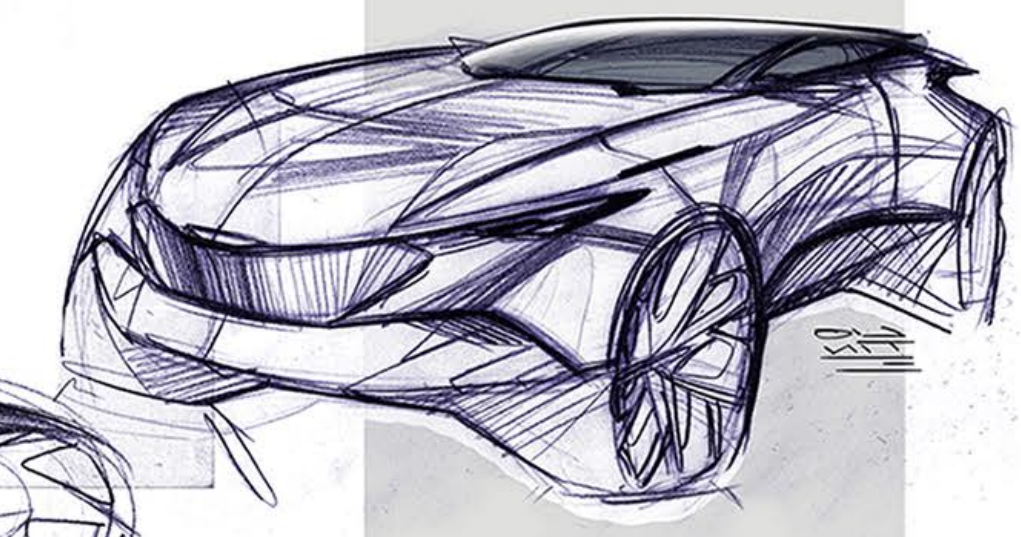

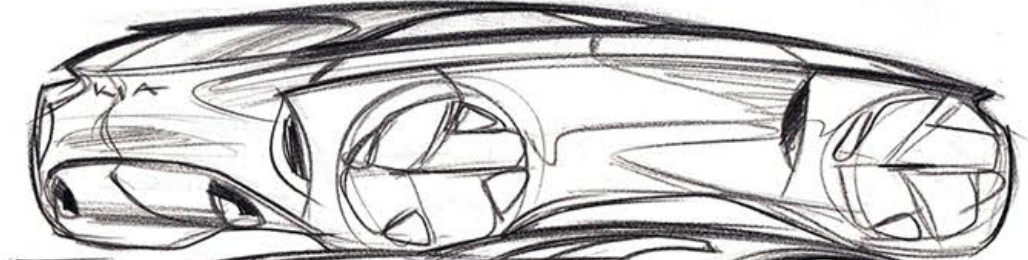
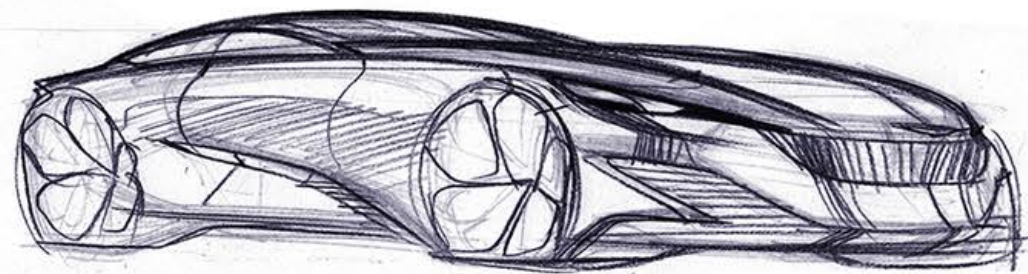
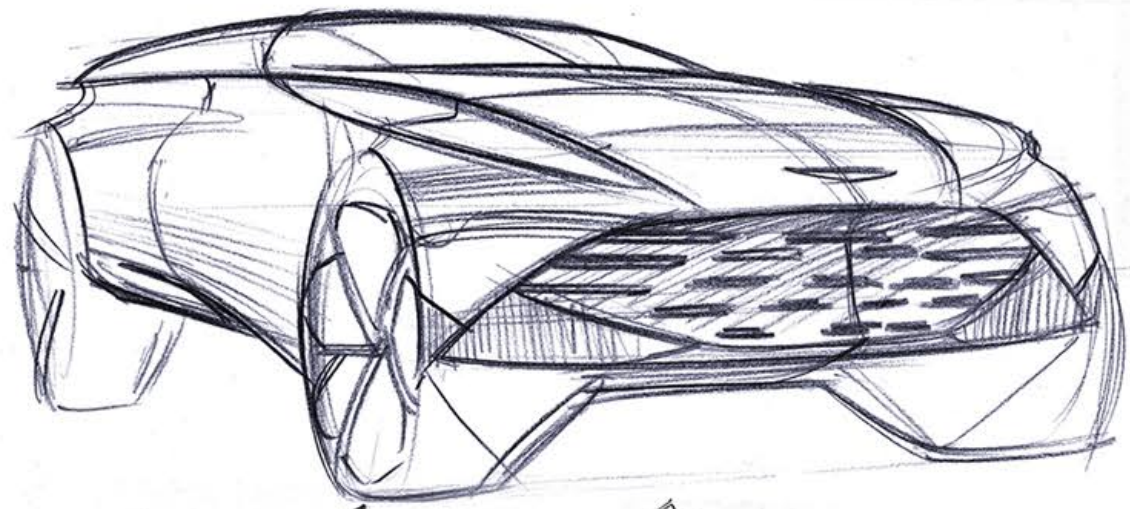

07
11/11

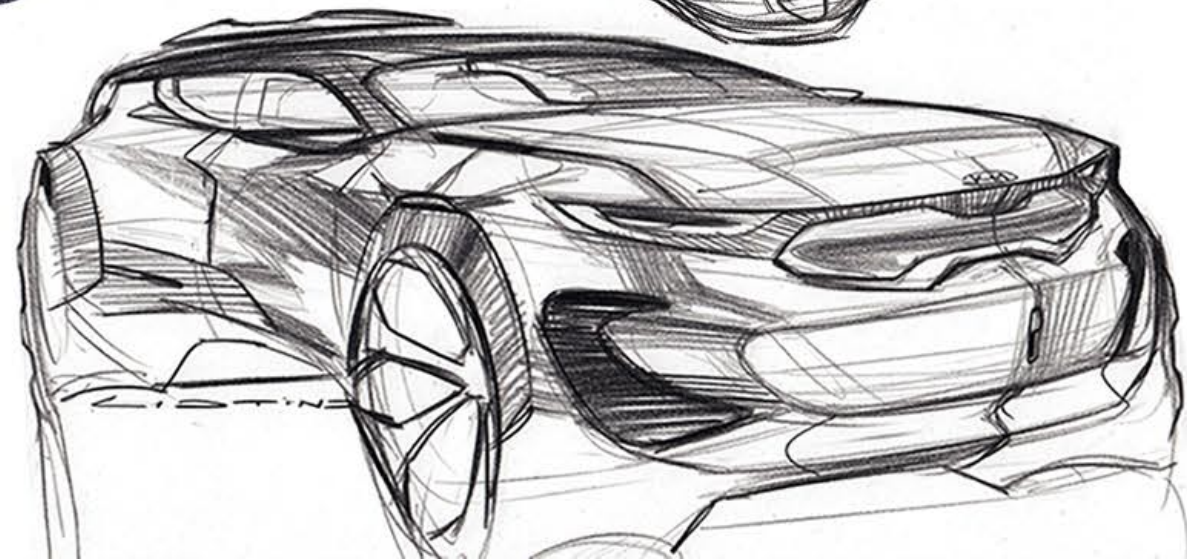
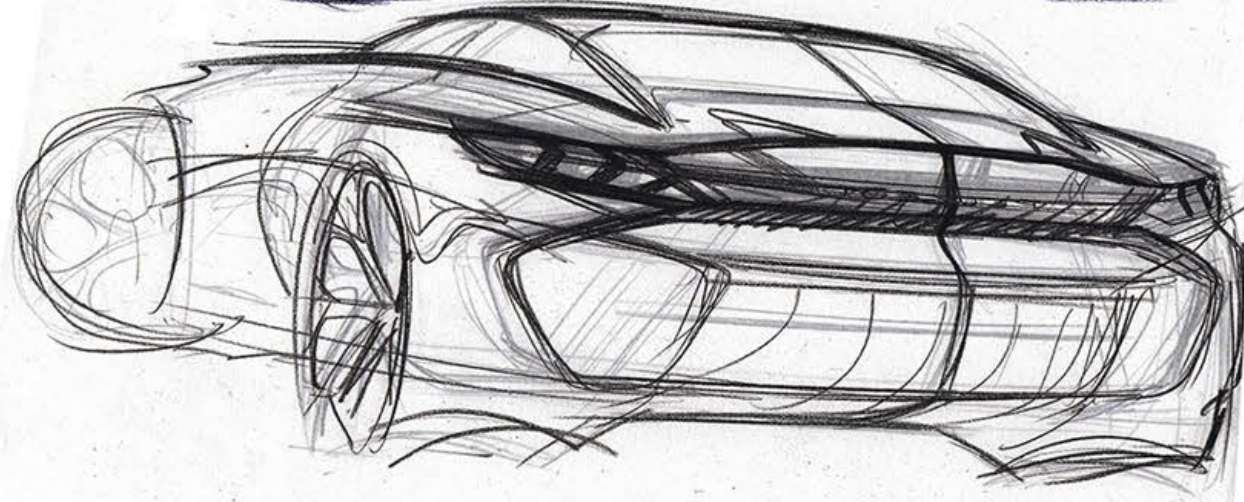
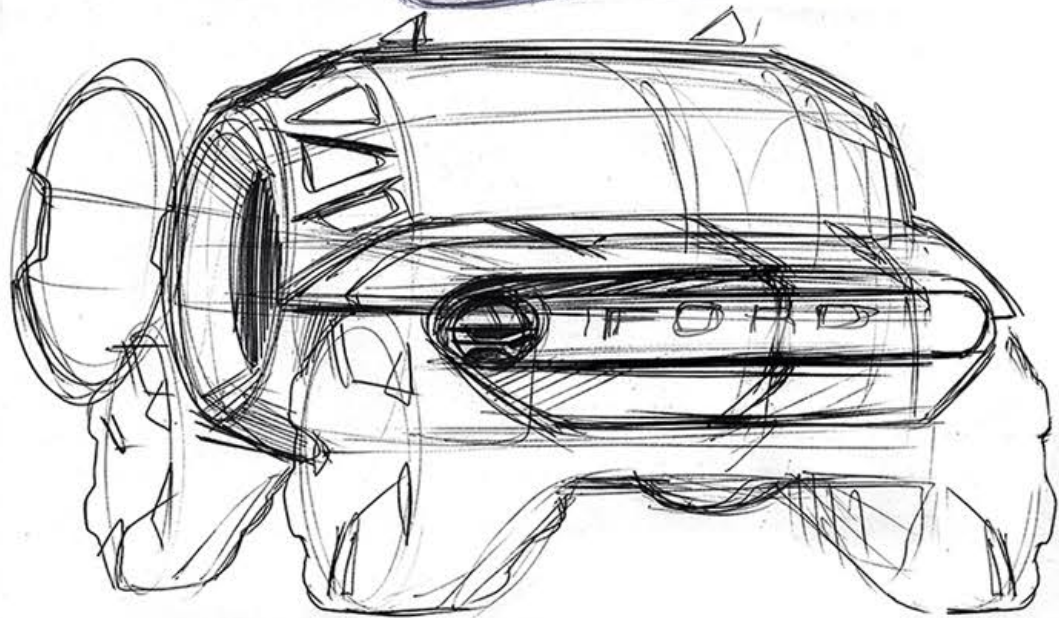
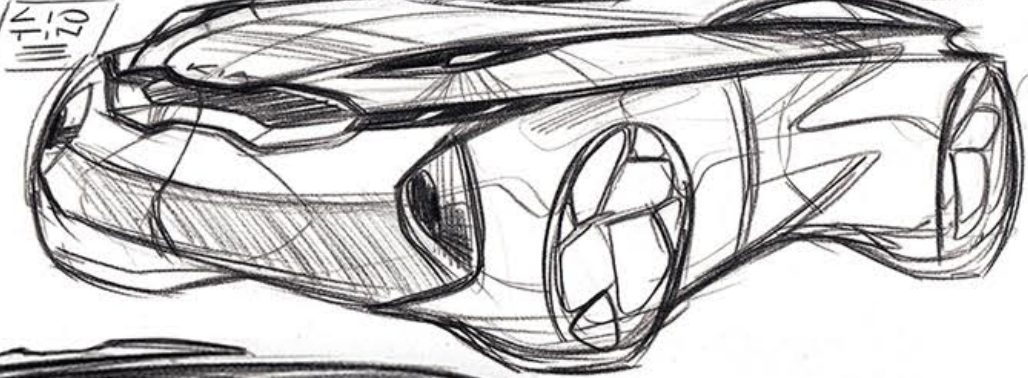
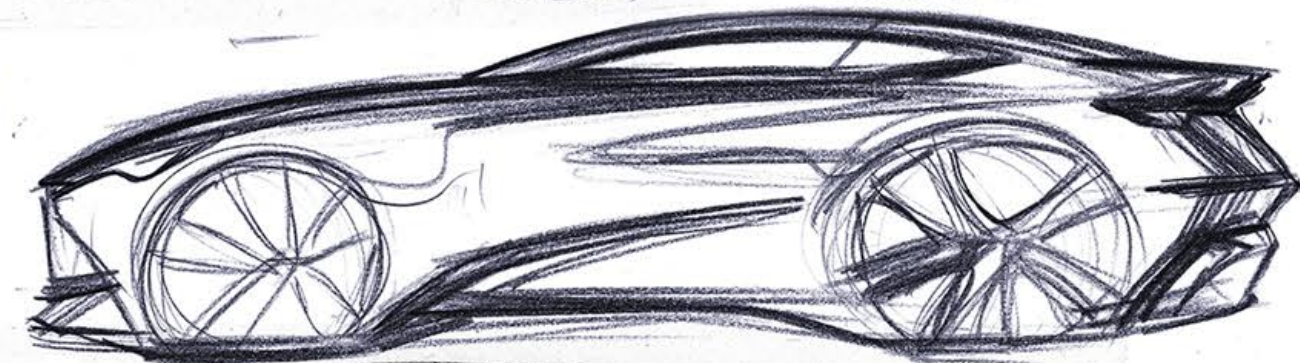

THANKS FOR YOUR ATTENTION